

TAPTITE II[®] and Other TRILOBULAR[™] Products For Fastening Metals and Plastics

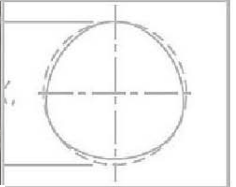
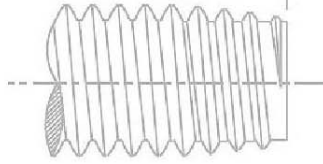
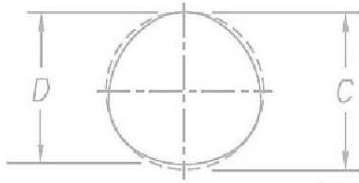

Leaders in Lowering the Cost of Assembly

Quick Reference Index TO THE TRILOBULAR® FAMILY OF "ENGINEERED FASTENINGS™"

TAPTITE II® SCREWS

Pages 4 & 5

Advantages

Applications



TAPTITE II® TRILOBULAR® thread-rolling screws roll-form strong, high integrity threads in drilled, punched or cored holes in ductile metals and castings. As each lobe of a TAPTITE II® screw moves through the pilot hole in the nut material, it forms and work-hardens the nut thread metal producing an uninterrupted grain flow. By elastic recovery, metal fills in behind the lobe, providing a greater area of thread contact with exceptional vibration resistance and fastening strength.

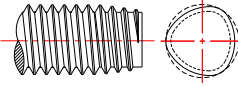

Practically eliminates chips. Low drive torque; high strip-to-drive ratio. Excellent resistance to vibrational loosening. Elimination of add-on locking devices. Reusable. Lower in-place fastener costs.

All ductile metals, die castings and punch extruded metals.

DUO-TAPTITE® SCREWS

Pages 6 & 7

Advantages

Applications



DUO-TAPTITE® TRILOBULAR® thread-rolling screws have generous lobulation at the screw point for easy entry and optimum forming action plus reduced lobulation in the screw body for increased holding power. A stabilizing thread insures ready, aligned entry into the pilot hole, with easy pickup and minimal starting end load. In extensive laboratory tests, DUO-TAPTITE® screws consistently surpass conventional thread-forming fasteners in every area of demanding performance.

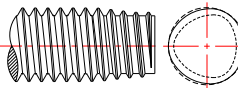

Easy entry, positive alignment and consistent starting stability. Lower starting end pressure. Higher strip-to-drive ratio. Higher prevailing torque. Excellent resistance to vibrational loosening.

All ductile metals, die castings and punch extruded metals.

EXTRUDE-TITE®, TAPTITE CA® SCREWS

Pages 5, 13 & 14

Advantages

Applications



TAPTITE® CA Point TRILOBULAR® thread rolling screws have a gimlet point for use when clearance holes and pilot holes are not in line. EXTRUDE-TITE® screws have less TRILOBULAR® shape and also have a gimlet point for use in more demanding sheet metal applications or in applications with minimal length of engagement. Either fastener can be supplied case hardened for normal use or as a CORFLEX®-I product for structural applications.

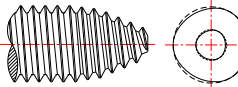

Low starting torque and initial end load, desirable features with large diameter fasteners, are provided by a second thread forming taper and by the TAPTITE II® step in the point. Vibration resistant.

For extremely rapid hole finding; for applications with floating nut members; where clearance and pilot holes are initially out of line; or where a sheet of material (gasket, carpet) must be pierced.

POWERLOK®, KLEERLOK® SCREWS

Pages 15 & 16

Advantages

Applications



POWERLOK® TRILOBULAR®, thread-locking screws incorporate unique threads dimensioned to provided locking in tapped holes. A 30° thread-locking crest is superimposed on the normal 60° thread. This design, including a short tapered lead, allows hand starting in a tapped hole, adjustment and alignment of parts, and an exceptionally powerful locking action.

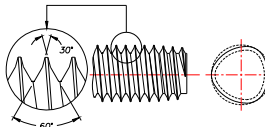

Locking action at thread periphery provides optimum holding power, even without seating of the head. Easy starting by hand and easy driving. Exceeds IFI locking standards. Extreme resistance to vibrational loosening.

All pre-tapped metal nuts, die castings and punch extruded assemblies where reliable, self-locking fasteners are required under conditions of severe vibration or high clamp load.

PLASTITE 45®, 48-2 SCREWS

Pages 17, 18 & 19

Advantages

Applications



PLASTITE® 45 TRILOBULAR® thread rolling screws have extra wide spacing between narrow profile threads, resulting in exceptionally low induced stress and extra low boss bursting tendencies. TRILOBULAR® thread form design provides full relief for easy driving and effective resistance to vibrational loosening. PLASTITE® 45 screws provide wide differential between drive and fail torques for exceptionally easy drive tool adjustment. Screws are manufactured to nominal inch and metric diameters.

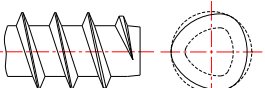

Easy driving. Excellent holding power. Reduced danger of burst bosses and induced stress. Easy power tool adjustment. Stronger internal threads: formed, not cut. No chips produced. Greater holding power. Reduced hoop stress and fewer burst bosses. Higher holding torque eliminates need for inserts or reinforcing clips. Allows for repeated removal and insertion.

Thermoplastics, engineering resins & certain thermosets. In cases where length of engagement is one diameter or more.

PUSHTITE® II SCREWS

Page 20

Advantages

Applications



PUSHTITE® II thread-forming fasteners are designed to be pressed into recommended hole sizes with a single, straight-line stroke. They have a TRILOBULAR® thread form combined with a 70°-10° semi-buttress thread shape to permit easy straight-line entry and provide exceptional pullout resistance. Threads are helical, not annular, permitting displaced air to escape during insertion. The helical thread also allows the fasteners to be removed and reinserted, if necessary. The TRILOBULAR® shape insures high prevailing off-torque.

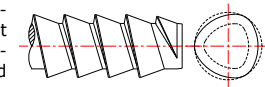

Fast installation. No drive torque or torque related problems and costs. Easy removal and reinsertion. Fewer burst bosses. Reduced in-place costs.

The resilient thermoplastics and several engineering grades. Component and boss design should allow for the stroke force.

CORFLEX® - TAPTITE II® SCREWS or DUO-TAPTITE® SCREWS AND BOLTS

Page 21

Advantages

Applications

CORFLEX® TRILOBULAR® thread-rolling screws combine good bending toughness, resistance to high alternating load stresses and ability to easily form threads in deep, untapped holes, with excellent resistance to vibrational loosening. These high-durability, structural screws are made from alloy steel, neutral-hardened to individual specifications, such as SAE grades 5 or 8 or metric 9.8 and 10.9. Thread-forming lead threads are induction hardened for thread-rolling capability.

Excellent resistance to shock and alternating loads. TRILOBULAR® thread-forming capability in heavy sections. Custom heat-treated to specific hardness/toughness requirements.

Recommended for critical or structural assemblies subject to vibration, shear stress, alternating loads, stress corrosion and rapid temperature fluctuations. For use when a neutral-hardened thread rolling screw is preferred over a conventional carburized and tempered fastener.



***Originators of the TRILOBULAR® Family of Fasteners
Providing Technical Support, Marketing Support and
Innovative Fastener Design***

Reduced In-Place Cost!!

TAPTITE II® and DUO-TAPTITE® thread rolling screws reduce in-place fastener costs and provide vibration resistant assemblies. TAPTITE II® and DUO-TAPTITE® thread rolling screws are used to create strong, uniform load carrying internal threads into untapped nut members upon installation. When REMINC/CONTI developed the original TAPTITE® TRILOBULAR® shape thread rolling screw, it revolutionized the use of threaded fasteners in high production assembly. Assembly efficiency and joint performance along with lower in-place fastening cost, have been the benefits of using TAPTITE® screws. TAPTITE II® and DUO-TAPTITE® screws and bolts continue these benefits along with meeting the quality and performance needs of the future.

Lower In-Place Fastening Costs

Only 15% of the total in-place cost of a fastening is the cost of the screw or bolt. TAPTITE II® and DUO-TAPTITE® screws and bolts lower the cost of the remaining 85%. The following is a list of some of the cost-savings advantages of using TAPTITE II® and DUO-TAPTITE® thread rolling screws.

- Elimination of separate tapping operations and associated costs.
- Built-in resistance to vibrational loosening eliminates the need for lock washers, adhesives, or plastic patches and plugs.
- Generates stronger mating threads with uninterrupted grain flow due to work hardening of the nut for higher stripping resistance.
- Accepts larger pilot hole variations than drilled and tapped holes.
- Works in punched, drilled, cored and extruded holes in many different metals.
- With use of CORFLEX® metallurgy, can be provided in grade strengths of high tensile bolts for use in structural applications in deep thread lengths of engagement.
- No assembly line cross threading.
- Prevailing torque often equals or exceeds locking screw standards.
- Manufactured to REMINC/CONTI standards all over the world by over 68 of the world's leading fastener, fastener processing and tooling companies.

TAPTITE II® Screws and Bolts



Percent thread chart Page 8
 Pilot hole sizes Page 9
 Typical torque performance .. Page 10
 Typical single punch
 extruded holes Pages 11 & 12
 Die cast cored holes Page 12
 CORFLEX® Page 21
 General Information Page 22

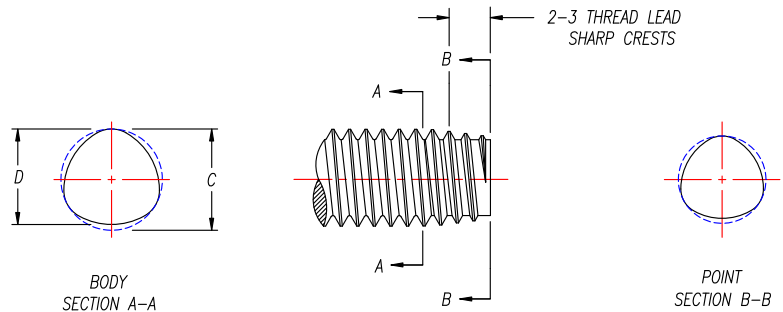

Length Tolerance - Inch - Per ANSI B18.6.3

Nominal Screw Length	Nominal Screw Size	
	#4 - #12	1/4" - 1/2"
Tolerance On Length		
To 1/2" Inclusive	+0, - .020	+0, - .030
Over 1/2" to 1" Inclusive	+0, - .030	+0, - .030
Over 1" to 2" Inclusive	+0, - .060	+0, - .060
Over 2"	+0, - .090	+0, - .090

Length Tolerance - Metric Per ANSI B18.6.7M

Nominal Screw Length	Tolerance on Length mm
to 3mm incl	± 0.2
over 3 to 10mm	± 0.3
over 10 to 16mm	± 0.4
over 16 to 50mm	± 0.5
over 50mm	± 1.0

NOMINAL SCREW SIZE	SCREW BODY DIMENSIONS			
	Max. C	Min. C	Max. D	Min. D
Metric Sizes (mm)				
M1.6 x 0.35	1.66	1.58	1.59	1.51
M2.0 x 0.40	2.06	1.98	1.98	1.90
M2.5 x 0.45	2.57	2.48	2.48	2.39
M3.0 x 0.50	3.07	2.98	2.97	2.88
M3.5 x 0.60	3.58	3.48	3.46	3.36
M4.0 x 0.70	4.08	3.98	3.94	3.84
M4.5 x 0.75	4.59	4.48	4.44	4.33
M5.0 x 0.80	5.09	4.98	4.93	4.82
M6.0 x 1.00	6.10	5.97	5.90	5.77
M7.0 x 1.00	7.10	6.97	6.90	6.77
M8.0 x 1.25	8.13	7.97	7.88	7.72
M10 x 1.50	10.15	9.97	9.85	9.67
M12 x 1.75	12.18	11.97	11.83	11.62
M14 x 2.00	14.20	13.97	13.80	13.57
M16 x 2.00	16.20	15.97	15.80	15.57

Inch Sizes (in)				
00-90	0.0481	0.0451	0.0461	0.0431
0-80	0.0613	0.0583	0.0588	0.0558
1-64	0.0745	0.0715	0.0715	0.0685
2-56	0.0875	0.0835	0.0840	0.0800
3-48	0.1010	0.0970	0.0970	0.0930
4-40	0.1145	0.1105	0.1095	0.1055
5-40	0.1275	0.1235	0.1225	0.1185
6-32	0.1410	0.1350	0.1350	0.1290
8-32	0.1670	0.1610	0.1610	0.1550
10-24	0.1940	0.1880	0.1860	0.1800
10-32	0.1930	0.1870	0.1870	0.1810
12-24	0.2200	0.2140	0.2120	0.2060
1/4-20	0.2550	0.2490	0.2450	0.2390
5/16-18	0.3180	0.3120	0.3070	0.3010
3/8-16	0.3810	0.3750	0.3685	0.3625
7/16-14	0.4445	0.4385	0.4305	0.4245
1/2-13	0.5075	0.5015	0.4920	0.4860
9/16-12	0.5710	0.5630	0.5540	0.5460
5/8-11	0.6340	0.6260	0.6160	0.6080

TAPTITE II® Thread Rolling Screws

TAPTITE II® thread rolling screws have the TRILOBULAR® shape which reduces friction during thread forming, provides prevailing torque which exceeds the level of locking screws, and most importantly, inherently provides resistance to vibrational loosening.

The TRILOBULAR® engineering principles used to create TAPTITE II® screws create an efficient thread rolling screw in all sizes and pitches allowing the manufacture and efficient use of production screws in Sizes 00/M1 to as large as 1"/M24. Only TAPTITE II® screws can make this claim. Competing designs are not typically manufactured above M5 size and certainly not available up to M24 as are TAPTITE II® screws.

To utilize the in-place cost savings and performance benefits of TAPTITE II® screws in large sizes in structural applications, the combination of CORFLEX®-'Y' selective hardening (See Page 21) is highly beneficial. CORFLEX®-'Y' TAPTITE II® bolts can be used where high-strength grade-strength level bolts are required.

“The Controllable Product™”

Why TAPTITE II[®] Over TAPTITE[®] Screws?

TAPTITE II[®] screws bring benefits to both fastener manufacturer and end user. TAPTITE II[®] screws were designed to:

- Provide a more efficient manufacturing method and tool design to result in a more consistent product.
- Be applicable to the quality and SPC philosophies of today’s market by utilizing the capabilities of today’s state of the art tooling and fastener manufacturing equipment.
- Provide more consistent torque performance, lower thread forming torque and lower end load necessary to initiate thread forming, than any other thread forming or thread rolling screw including the original TAPTITE[®] screw.

Behind the scenes, REMINC/CONTI has provided its licensed manufacturers with a total quality system for manufacturing TAPTITE II[®] fasteners. Included are design and processing failure mode and effects analysis procedures, statistical in process control data collection system, and improved inspection procedures and criteria. Although all REMINC/CONTI products are designed for consistent manufacture and performance, TAPTITE II[®] fasteners were physically re-designed to meet the above quality system, to be the quality flagship of TRILOBULAR[®] products.

Note: TAPTITE II[®] is often designated TYPE TT[®] AND TT-II[™]



REMINC/CONTI Statistical Process Control Electronic Data Collection System for TRILOBULAR[®] Products.

TAPTITE[®] “CA” Screws with Step Taper “CA” Point

TAPTITE[®] “CA” screws are for applications with floating nut members or in situations where clearance and pilot holes may not line up initially and where rapid hole finding is essential. Low initial end load is provided by the second taper and TAPTITE II[®] step, a particularly desirable feature with larger diameters.

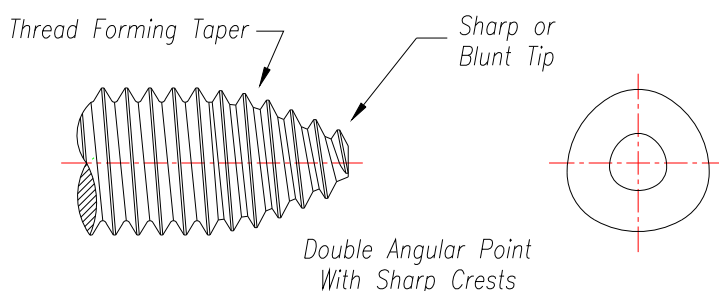

DUO-TAPTITE® Screws and Bolts



Percent thread chart Page 8
 Pilot hole sizes Page 9
 Typical torque performance .. Page 10
 Typical single punch
 extruded holes Pages 11 & 12
 Die cast cored holes Page 12
 CORFLEX® Page 21
 General Information Page 22

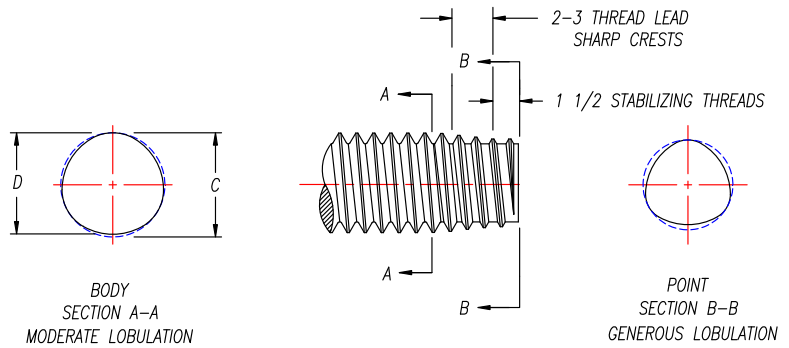

Length Tolerance - Inch - Per ANSI B18.6.3		
Nominal Screw Length	Nominal Screw Size	
	#4 - #12	1/4" - 1/2"
Tolerance On Length		
To 1/2" Inclusive	+0, - .020	+0, - .030
Over 1/2" to 1" Inclusive	+0, - .030	+0, - .030
Over 1" to 2" Inclusive	+0, - .060	+0, - .060
Over 2"	+0, - .090	+0, - .090

Length Tolerance - Metric Per ANSI B18.6.7M	
Nominal Screw Length	Tolerance on Length mm
to 3mm incl	± 0.2
over 3 to 10mm	± 0.3
over 10 to 16mm	± 0.4
over 16 to 50mm	± 0.5
over 50mm	± 1.0

SCREW SIZE	SCREW BODY DIMENSIONS			
	Max.	Min.	Max.	Min.
Metric Sizes (mm)				
M2.5 x 0.45	2.57	2.48	2.52	2.44
M3.0 x 0.50	3.07	2.98	3.02	2.93
M3.5 x 0.60	3.58	3.48	3.52	3.42
M4.0 x 0.70	4.08	3.98	4.01	3.91
M4.5 x 0.75	4.59	4.48	4.51	4.41
M5.0 x 0.80	5.09	4.98	5.01	4.90
M6.0 x 1.00	6.10	5.97	6.00	5.87
M7.0 x 1.00	7.10	6.97	7.00	6.87
M8.0 x 1.25	8.13	7.97	8.00	7.85
M10 x 1.50	10.15	9.97	10.00	9.82
M12 x 1.75	12.18	11.97	12.00	11.80
M14 x 2.00	14.20	13.97	14.00	13.77
M16 x 2.00	16.20	15.97	16.00	15.77

Inch Sizes (in)				
2-56	0.0875	0.0835	0.0855	0.0815
3-48	0.1010	0.0970	0.0990	0.0950
4-40	0.1145	0.1105	0.1120	0.1080
5-40	0.1275	0.1235	0.1250	0.1210
6-32	0.1410	0.1350	0.1380	0.1320
8-32	0.1670	0.1610	0.1640	0.1580
10-24	0.1940	0.1880	0.1900	0.1840
10-32	0.1930	0.1870	0.1900	0.1840
12-24	0.2200	0.2140	0.2160	0.2100
1/4-20	0.2550	0.2490	0.2500	0.2440
5/16-18	0.3180	0.3120	0.3125	0.3065
3/8-16	0.3810	0.3750	0.3745	0.3685
7/16-14	0.4445	0.4385	0.4375	0.4315
1/2-13	0.5075	0.5015	0.5000	0.4940
9/16-12	0.5710	0.5630	0.5625	0.5545
5/8-11	0.6340	0.6260	0.6250	0.6170

DUO-TAPTITE® Thread Rolling Screws

TAPTITE® screws were the leap forward in high production assembly using threaded fasteners. DUO-TAPTITE® screws represent the refinement of the TRILOBULAR® principle for specific demanding applications.

DUO-TAPTITE® screws have generous lobulation at the screw point for easy entry and optimum thread forming action plus reduced lobulation in the screw body holding area. A stabilizing threaded dog point insures ready, aligned entry, with easy pick-up requiring minimal starting end load.

ADVANTAGES

- High vibrational resistance
- Good axial alignment
- Low end load
- High strip-to-drive ratio
- High prevailing torque
- Good torque tension relationship



DUO-TAPTITE® Screws and Bolts

Better starting stability – Axial Alignment

Less misalignment at start of driving operation . . . the self-aligning characteristic of DUO-TAPTITE® screws reduces operator fatigue; eliminates interruptions in production; adds speed to every fastening operation. Suitable for automated and robotic assembly.

B – Higher prevailing torque

Superior elastic action of a DUO-TAPTITE® screw gives it better locking characteristics than many fasteners specifically designed as locking screws! Competitive round-bodied, thread-forming fasteners have no locking torque. Graph shows comparison of DUO-TAPTITE® screw with IFI-124 minimum requirement for self-locking screws.

TYPICAL ANGULARITY

DUO-TAPTITE®	COMPETITIVE ROUND-BODIED THREAD-FORMING SCREW
2°	5°
1°	3°
2°	4°
2°	2°

** Starting angle of four specimens of each type measured at 20x full size on an optical comparator.

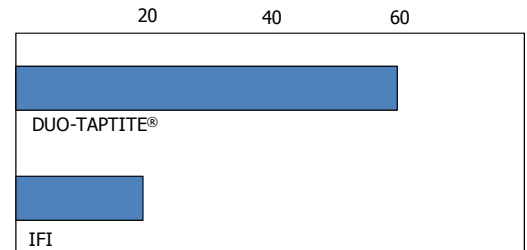

Result is an average of samples tested

Lower starting end pressure

Lower starting end pressure combines with lower driving torque to reduce time and power costs right down the line.

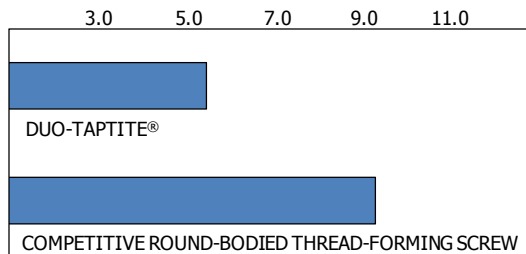

Result is an average of samples tested

Torque-tension comparison M8 x 1.25 DUO-TAPTITE® vs. TAPTITE® Fastener

Superior tension at any given applied torque (with normal clamping pressure) is a major factor in the better holding capability of a DUO-TAPTITE® screw.

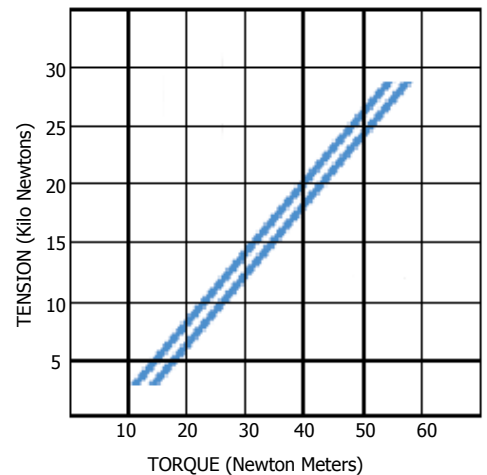

NOTE: This graph represents a linear calculation based on statistical data of the respective screws

A – Higher strip-to-drive ratio

The higher, more uniform, strip-to-drive torque ratio of DUO-TAPTITE® screws provides a built-in safety factor against over-driving. Eliminates broken screws, damaged mating threads and inferior fastenings.

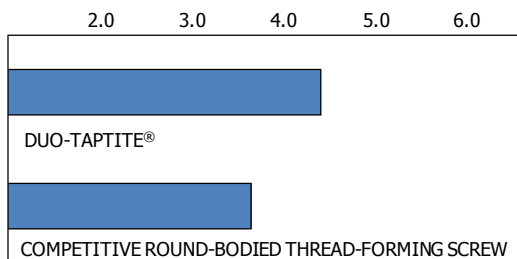

Result is an average of samples tested

NOTE: All screws were tested in unthreaded weld nuts of uniform hardness (Rockwell B 82-84) having 7.1mm hole diameters. End pressure was manually developed, measured and recorded by an electronic load cell and recorder. Drive, prevailing and strip torque values, and torque-tension values were measured with a GSE torque cell and recorded on a BLH electronic recorder. All test data is based on 5/16 - 18 or M8 x 1.25 screws.

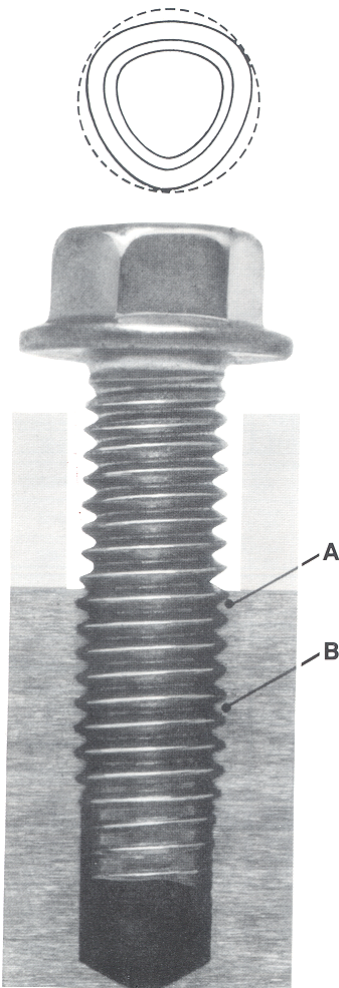

DUO-TAPTITE® fasteners, and/or their manufacture according to REMINC/CONTI specifications, covered by one or more of the following patents: 6,089,806, 6,089,986, 6,261,040.

Hole Size Information



Suggested hole sizes for TAPTITE II[®], DUO-TAPTITE[®] and TAPTITE[®] CA Screws and bolts at various percentages of thread engagement

Metric Sizes (mm)

NOMINAL SCREW SIZE	PERCENT THREAD													
	100	95	90 (1)	85 (1)	80	75	70	65	60	55	50	45	40	35
	PILOT HOLE SIZES													
M2.5 x 0.45	2.21	2.22	2.24	2.25	2.27	2.28	2.29	2.31	2.32	2.34	2.35	2.37	2.38	2.40
M3 x 0.5	2.67	2.69	2.71	2.72	2.74	2.76	2.77	2.79	2.80	2.82	2.84	2.85	2.87	2.90
M3.5 x 0.6	3.11	3.13	3.15	3.17	3.19	3.21	3.23	3.25	3.27	3.29	3.30	3.32	3.34	3.36
M4 x 0.7	3.54	3.57	3.59	3.61	3.64	3.66	3.68	3.70	3.73	3.75	3.77	3.79	3.80	3.84
M4.5 x 0.75	4.01	4.04	4.06	4.09	4.11	4.13	4.16	4.18	4.21	4.23	4.26	4.28	4.30	4.33
M5 x 0.8	4.48	4.51	4.53	4.56	4.58	4.61	4.64	4.66	4.69	4.71	4.74	4.77	4.79	4.82
M6 x 1.0	5.35	5.38	5.42	5.45	5.48	5.51	5.54	5.58	5.61	5.64	5.67	5.71	5.74	5.77
M6.3 x 1.0	5.65	5.68	5.72	5.75	5.78	5.81	5.84	5.88	5.91	5.94	5.97	6.01	6.04	6.07
M7 x 1.0	6.35	6.38	6.42	6.45	6.48	6.51	6.54	6.58	6.61	6.64	6.67	6.71	6.74	6.77
M8 x 1.25	7.19	7.23	7.27	7.31	7.35	7.39	7.43	7.47	7.51	7.55	7.59	7.63	7.67	7.72
M10 x 1.5	9.03	9.07	9.12	9.17	9.22	9.27	9.32	9.37	9.41	9.46	9.51	9.56	9.61	9.66
M12 x 1.75	10.86	10.92	10.98	11.03	11.09	11.15	11.20	11.26	11.31	11.37	11.43	11.49	11.55	11.60

Inch Sizes (in)

NOMINAL SCREW SIZE	PERCENT THREAD													
	100	95	90 (1)	85 (1)	80	75	70	65	60	55	50	45	40	35
	PILOT HOLE SIZES													
2-56	.0744	.0750	.0756	.0761	.0767	.0773	.0779	.0785	.0790	.0796	.0802	.0808	.0814	.0819
3-48	.0855	.0861	.0868	.0875	.0882	.0888	.0895	.0902	.0909	.0916	.0922	.0929	.0936	.0943
4-40	.0958	.0966	.0974	.0982	.0990	.0998	.1006	.1014	.1023	.1031	.1039	.1047	.1055	.1063
5-40	.1088	.1096	.1104	.1112	.1120	.1128	.1136	.1144	.1153	.1161	.1169	.1177	.1185	.1193
6-32	.1177	.1187	.1197	.1207	.1218	.1228	.1238	.1248	.1258	.1268	.1278	.1289	.1299	.1309
8-32	.1437	.1447	.1457	.1467	.1478	.1488	.1498	.1508	.1518	.1528	.1538	.1549	.1559	.1569
10-24	.1629	.1643	.1656	.1670	.1683	.1697	.1710	.1724	.1738	.1751	.1765	.1778	.1792	.1805
10-32	.1697	.1707	.1717	.1727	.1738	.1748	.1758	.1768	.1778	.1788	.1798	.1809	.1819	.1829
12-24	.1889	.1903	.1916	.1930	.1943	.1957	.1970	.1984	.1998	.2011	.2025	.2038	.2052	.2065
1/4-20	.2175	.2191	.2208	.2224	.2240	.2256	.2273	.2289	.2305	.2321	.2338	.2354	.2370	.2386
5/16-18	.2764	.2782	.2800	.2818	.2836	.2854	.2872	.2890	.2908	.2926	.2944	.2963	.2981	.2999
3/8-16	.3344	.3364	.3384	.3405	.3425	.3445	.3466	.3486	.3506	.3527	.3547	.3567	.3588	.3608
7/16-14	.3911	.3934	.3957	.3980	.4004	.4027	.4050	.4073	.4096	.4120	.4143	.4166	.4189	.4213
1/2-13	.4500	.4525	.4550	.4575	.4600	.4625	.4650	.4675	.4700	.4725	.4750	.4775	.4800	.4825

EXAMPLE - The shaded area indicates that an M5 - 0.8 screw size in a 4.58 hole size provides 80% thread engagement.

Because the above values are based on a linear relation between hole size and percentage thread engagement, the hole data becomes less accurate for engagements less than 70%.

Note also, these hole sizes are based on the U.S. basic thread depth of .6495 times the pitch and are calculated using nominal screw diameters.

Hole = D - (0.6495 x P x %), where D = nominal screw diameter.

(1) Pilot holes listed under 90% & 85% (Thread Percent) also recommended for single punch extruded holes. See Page 11

For Pilot Hole Tolerance in terms of thread percentage, we suggest +5% to -10% of the nominal value, percent thread value.

EXAMPLE: If 80% is the percent thread for the nominal hole, the minimum hole would yield 85% thread and the maximum hole would yield 70% thread.

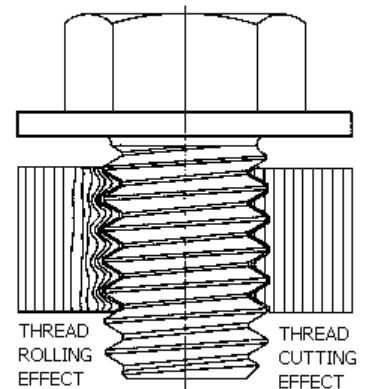



Hole Size Information

Recommended pilot hole sizes for TAPTITE II[®], DUO-TAPTITE[®] and TAPTITE[®] CA Screws and bolts for steel nut member thicknesses

(Expressed in terms of screw diameters)

Metric Sizes (mm)

Application Duty Class	Light 0.3 Diameter of Material			Medium-Light 0.5 Diameter of Material			Medium-Heavy 0.75 Diameter of Material			Full Strength 1.0 Diameter of Material			Extended 1.25 Diameter of Material		
Percentage of Thread	90%			85%			80%			75%			70%		
Nominal Size	Material Thickness	Pilot Hole	Drill Size	Material Thickness	Pilot Hole	Drill Size	Material Thickness	Pilot Hole	Drill Size	Material Thickness	Pilot Hole	Drill Size	Material Thickness	Pilot Hole	Drill Size
M2.5 x 0.45	0.5-0.9	2.24	2.25	0.9-1.5	2.25	2.25	1.5-2.1	2.27	#43 2.26	2.1-2.7	2.28	#43 2.26	2.7-3.5	2.30	2.30
M3 x 0.5	0.5-1.1	2.71	#36 2.71	1.1-1.7	2.72	#36 2.71	1.7-2.7	2.74	2.75	2.7-3.3	2.76	2.75	3.3-4.0	2.77	7/64" 2.78
M3.5 x 0.6	0.6-1.4	3.15	1/8" 3.18	1.4-2.0	3.17	1/8" 3.18	2.0-2.9	3.19	3.20	2.9-3.8	3.21	3.20	3.8-4.5	3.23	3.25
M4 x 0.7	0.8-1.4	3.59	3.60	1.4-2.4	3.61	3.60	2.4-3.3	3.64	#27 3.66	3.3-4.4	3.66	#27 3.66	4.4-5.5	3.68	3.70
M4.5 x 0.75	0.9-1.7	4.06	#21 4.04	1.7-2.7	4.09	#20 4.09	2.7-3.9	4.11	4.10	3.9-4.9	4.13	4.10	4.9-6.4	4.16	4.20
M5 x 0.8	1.0-2.1	4.53	4.50	2.1-2.9	4.56	#15 4.57	2.9-4.4	4.58	#15 4.57	4.4-5.9	4.61	4.60	5.9-7.1	4.64	#14 4.62
M6 x 1.0	1.2-2.4	5.42	#3 5.41	2.4-3.6	5.45	#3 5.41	3.6-4.9	5.48	5.50	4.9-6.9	5.51	5.50	6.9-8.1	5.55	7/32" 5.56
M6.3 x 1.0	1.3-2.4	5.72	5.70	2.4-3.7	5.75	5.75	3.7-4.9	5.78	5.75	4.9-7.4	5.81	5.80	7.4-8.9	5.85	5.80
M7 x 1.0	1.4-2.4	6.42	6.40	2.4-4.4	6.45	6.40	4.4-6.5	6.48	6.50	6.4-7.7	6.51	6.50	7.7-9.5	6.55	F 6.53
M8 x 1.25	1.6-3.1	7.27	7.25	3.1-4.9	7.31	7.30	4.6-6.9	7.35	L 7.37	6.9-8.9	7.39	L 7.40	8.9-10.9	7.43	7.40
M10 x 1.5	1.9-3.9	9.12	23/64" 9.10	3.9-5.9	9.17	9.20	5.9-8.3	9.22	9.20	8.3-10.9	9.27	9.25	10.9-12.9	9.32	9.30
M12 x 1.75	2.4-4.9	10.98	11.00	4.9-7.4	11.03	11.00	7.4-10.5	11.09	7/16" 11.11	10.5-14.5	11.15	7/16" 11.11	14.5-17.0	11.2	7/16" 11.11

Inch sizes (in)

Application Duty Class	Light 0.3 Diameter of Material			Medium-Light 0.5 Diameter of Material			Medium-Heavy 0.75 Diameter of Material			Full Strength 1.0 Diameter of Material			Extended 1.25 Diameter of Material		
Percentage of Thread	90%			85%			80%			75%			70%		
Nominal Size	Material Thickness	Pilot Hole	Drill Size	Material Thickness	Pilot Hole	Drill Size	Material Thickness	Pilot Hole	Drill Size	Material Thickness	Pilot Hole	Drill Size	Material Thickness	Pilot Hole	Drill Size
2-56	.017-.034	.0756	1.9mm .0748	.034-.052	.0761	#48 .0760	.052-.073	.0767	1.95mm .0763	.073-.095	.0773	5/64 .0781	.095-.169	.0779	5/64 .0781
3-48	.020-.040	.0860	2.2mm .0866	.040-.059	.0875	2.2mm .0866	.059-.084	.0882	#43 .0890	.084-.110	.0888	#43 .0890	.110-.141	.0895	#43 .0890
4-40	.022-.045	.0974	#40 .0980	.045-.067	.0982	#40 .0980	.067-.095	.0990	#39 .0995	.095-.126	.0998	#39 .0995	.126-.157	.1006	#39 .0995
5-40	.025-.051	.1104	2.8mm .1102	.051-.075	.1112	#34 .1110	.075-.106	.1120	#33 .1130	.106-.141	.1128	#33 .1130	.141-.175	.1136	#33 .1130
6-32	.028-.066	.1197	#31 .1200	.066-.083	.1207	#31 .1200	.083-.117	.1218	3.1mm .1220	.117-.152	.1288	3.1mm .1220	.152-.193	.1238	1/8 .1250
8-32	.033-.066	.1457	3.7mm .1457	.066-.098	.1467	#26 .1470	.098-.141	.1478	3.75mm .1476	.141-.180	.1488	3.8mm .1496	.180-.230	.1498	3.8mm .1496
10-24	.038-.079	.1656	#19 .1660	.079-.114	.1670	4.25mm .1673	.114-.162	.1683	#18 .1695	.162-.209	.1697	#18 .1695	.209-.266	.1710	11/64 .1719
10-32	.038-.079	.1717	11/64 .1719	.079-.114	.1727	#17 .1730	.114-.162	.1738	#17 .1730	.162-.209	.1748	4.4mm .1732	.209-.266	.1758	#16 .1770
12-24	.043-.086	.1916	#11 .1910	.086-.130	.1930	4.9mm .1929	.130-.184	.1943	#9 .1960	.184-.238	.1957	#9 .1960	.238-.302	.1970	5mm .1969
1/4-20	.050-.100	.2208	#2 .2210	.100-.150	.2224	5.7mm .2244	.150-.213	.2240	5.7mm .2244	.213-.275	.2256	5.75mm .2264	.275-.350	.2273	#1 .2280
5/16-18	.062-.126	.2800	7.1mm .2795	.126-.188	.2818	9/32 .2812	.188-.266	.2836	7.2mm .2835	.266-.345	.2854	7.25mm .2854	.345-.438	.2872	7.3mm .2874
3/8-16	.075-.150	.3384	8.6mm .3386	.150-.225	.3405	8.6mm .3386	.225-.319	.3425	8.7mm .3425	.319-.413	.3445	8.75mm .3455	.413-.525	.3466	8.8mm .3465
7/16-14	.087-.174	.3957	X .3970	.174-.262	.3980	X .3970	.262-.371	.4004	X .3970	.371-.481	.4027	Y .4040	.481-.612	.4050	Y .4040
7/16-20	.087-.174	.4083	13/32 0.4062	.174-.262	.4099	13/32 0.4062	.262-.371	.4115	13/32 0.4062	.371-.481	.4131	Z 0.413	.481-.612	.4148	10.5mm 0.4134
1/2-13	.100-.200	.4550	29/64 .4531	.200-.300	.4575	29/64 .4531	.300-.425	.4600	29/64 .4531	.425-.550	.4625	15/32 .4688	.550-.700	.4650	15/32 .4688

Notes: This chart pertains to steel nut members

APPLICATION DUTY CLASS - A general term used here to group material thickness in terms of screw diameters. For example, the average material thickness listed under "medium-heavy" equals 75% of the screw diameter.



Typical Torque Performance of TAPTITE II® Screws in Cold Rolled Steel

Metric

Screw Size	Plate Thickness	Hole Size	Nearest Drill Size	Thread Forming Torque	Prevailing First Removal Torque	Recommended Assembly Torque	Failure Torque
M3 x 0.5	1.0	2.71	#36	.30-.45	.15-.30	1.0	1.5-2.0*
	2.0	2.75	2.75mm	.35-.55	.15-.30	1.0	1.6-2.5*
	3.0	2.75	2.75mm	.50-.80	.25-.40	1.6	2.5-3.5*†
M4 x 0.7	2.0	3.60	3.6mm	.60-.85	.30-.40	1.8	2.8-3.8*
	3.0	3.66	#27	.90-1.3	.50-.70	3.3	5.5-7.5
	4.0	3.66	#27	1.2-1.6	.60-.85	4.3	7.0-10.0
M5 x 0.8	2.5	4.57	#15	1.3-2.0	.60-.80	2.8	5.3-8.0*
	3.5	4.57	#15	1.5-2.7	.90-1.5	6.0	10-12*
	5.0	4.60	4.6mm	2.0-3.0	.90-1.5	7.0	11-14*†
M6 x 1.0	3.0	5.41	#3	2.0-2.8	.60-1.2	5.0	9-13*
	4.5	5.50	5.5mm	3.2-4.5	.90-1.5	10.0	16-21*
	6.0	5.50	5.5mm	3.5-4.8	1.0-1.7	10.0	18-25*†
M8 x 1.25	4.0	7.30	7.3mm	4.8-7.0	1.5-2.8	20.0	33-42*
	6.0	7.37	L	5.5-9.5	2.2-3.6	28.0	43-53*
	8.0	7.37	L	7.0-12	4.0-6.0	30.0	55-65†
M10 x 1.5	5.0	9.20	9.2mm	11-15	5.0-7.0	30.0	53-63*
	8.0	9.20	9.2mm	14-19	6.0-9.0	45.0	80-92*
	10.0	9.25	9.25mm	15-22	7.0-12	55.0	92-102*†
M12 x 1.75	6.0	11.00	11.0mm	23-29	7.0-13	60.0	108-130*
	9.0	11.11	7/16	25-31	9.0-15	65.0	115-135*
	12.0	11.11	7/16	30-38	13-20	100.0	175-200*†

Inch

Screw Size	Plate Thickness	Hole Size	Nearest Drill Size	Thread Forming Torque	Prevailing First Removal Torque	Recommended Assembly Torque	Failure Torque
2-56	0.0469	0.075	1.9mm	1-2	.5-1	4	6-7*
	0.0625	0.076	#48	1-2	.5-1	4	8-10*
	0.0938	0.079	#47	1-2	.5-1	5	11-14†
3-48	0.0625	0.087	2.2mm	3-4	1-2	6	14-15*
	0.0938	0.089	#43	3-5	1-2	7	15-16*
	0.1250	0.090	#43	4-6	1-2	7	15-18†
4-40	0.0312	0.098	#40	2-3	1-2	6	8-11*
	0.0625	0.102	2.6mm	3-4	1-2	9	15-18*
	0.0938	0.102	2.6mm	3-4	1-2	11	22-27†
5-40	0.0625	0.111	#34	4-5	2-3	12	22-29*
	0.0938	0.113	#33	4-7	3-4	18	34-41*
	0.1250	0.116	#32	6-8	4-5	20	38-46†
6-32	0.0625	0.120	#31	4-7	3-4	14	25-30*
	0.0938	0.120	#31	6-9	3-5	20	35-45*†
	0.1250	0.125	1/8	6-9	4-6	22	39-45†
8-32	0.0938	0.147	#26	10-13	5-7	30	65-75*
	0.1250	0.150	3.8mm	11-14	4-7	45	75-85*†
	0.1875	0.150	3.8mm	16-20	8-11	45	75-95†
10-24	0.0938	0.172	11/64	14-18	5-8	35	65-80*
	0.1250	0.172	11/64	14-18	5-8	45	80-90*
	0.1875	0.172	11/64	17-22	9-13	55	110-115†
10-32	0.0938	0.173	#17	11-14	9-13	35	80-95*
	0.1250	0.177	#16	12-16	9-13	50	110-120*
	0.1875	0.177	#16	19-25	12-16	70	115-140*
12-24	0.1250	0.196	#9	19-24	9-12	65	95-115*
	0.1875	0.199	#8	21-26	9-13	75	135-155*
	0.2500	0.203	13/64	21-26	10-14	85	150-170†
1/4-20	0.1250	0.224	5.7mm	30-36	18-25	85	170-195*
	0.1875	0.224	5.7mm	45-55	25-35	125	205-235†
	0.2500	0.228	#1	55-65	25-35	125	205-235†
5/16-18	0.1875	0.281	K	75-85	40-50	160	380-410*
	0.2500	0.285	7.25mm	75-85	40-50	225	425-465*†
	0.3125	0.285	7.25mm	80-90	55-65	250	450-500†
3/8-16	0.2500	0.348	S	90-100	45-55	350	825-875*
	0.3125	0.348	S	110-125	50-60	400	950-1000*
	0.3750	0.354	9mm	95-110	30-45	450	950-1000*
7/16-14	0.3125	0.404	Y	145-165	75-95	500	1000-1150*
	0.3750	0.406	13/32	145-170	60-90	600	1200-1350*
	0.5000	0.406	13/32	195-220	75-105	700	1400-1600†
1/2-13	0.2500	0.465	29/64	150-180	60-80	500	975-1075*
	0.3750	0.469	15/32	185-215	60-90	850	1600-1800*
	0.5000	0.469	15/32	235-275	75-105	1000	1900-2200†

NOTES:

- Torque values for metric sizes in Newton-meters
- Torque values for inch sizes in pound-inches
- Plate dimensions for metric sizes in millimeters and for inch sizes in inches
- Torque values were developed using hex washer head screws, zinc plated plus lubricity wax, driven at low speed under laboratory-controlled conditions.
- Values shown represent the above conditions only and should not be used in lieu of proper application testing. The data is presented to provide the user with an estimate of what could be achieved in an actual application having a thicker or thinner nut member harder or softer material, different hole or fastener all contribute to variations in torque performance.
- Recommended tightening torque is intended to induce approximately 30,000 to 50,000 psi clamping force.
- Prevailing first removal torque, the torque necessary to remove the screw after the head has been un-seated, is an indication of TAPTITE II® screws inherent resistance of free turning which is an indication of resistance to loosening under vibration, even without screw head being seated.

* Indicates probability that nut threads will strip.

† Indicates probability that screw will break.

Suggested extruded holes in light-gauge steel for TAPTITE II® and DUO-TAPTITE® Screws and Bolts

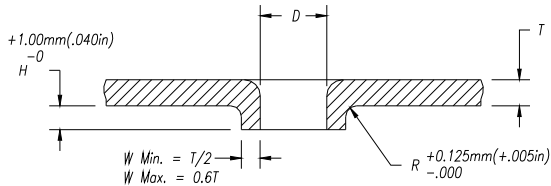

Extruding holes for fasteners in light-gauge steel nearly doubles the length of thread engagement over original material thickness.

TAPTITE II® and DUO-TAPTITE® screws and bolts will develop almost twice the failure torque in extruded holes, providing maximum joint integrity.

The areas of the upper chart indicate that an extruded hole diameter of .146" to .149" is suggested in .060" thick material when using a number 8-32 TAPTITE II® or DUO-TAPTITE® screw. The corresponding H dimension, shown on Page 12 for this hole will be .053" minimum, making the total length of engagement .113" minimum.

mm Thickness	0.5			0.8		1.1		1.6		2.4		3.6		4.4	4.75		5.5							
Inch Thickness		0.02	0.03		0.04		0.06		0.09		0.13		0.16			0.19		0.22	0.25	0.31	0.38			
Screw Size	HOLE SIZES - D																							
M2.5 x 0.45	2.21			2.22		2.25		2.27																
	2.24			2.26		2.28		2.30																
M3 x 0.50	2.68			2.71		2.74		2.77		2.80														
	2.71			2.74		2.77		2.80		2.83														
M3.5 x 0.6	3.11			3.13		3.16		3.19		3.24		3.27												
	3.15			3.18		3.21		3.24		3.29		3.32												
6-32		0.118	0.118		0.12		0.120		0.122															
		0.120	0.121		0.12		0.123		0.125															
M4 x 0.70				3.55		3.58		3.60		3.64		3.69												
				3.59		3.62		3.65		3.68		3.73												
8-32		0.14	0.14		0.15		0.15		0.147		0.148													
		0.15	0.15		0.15		0.15		0.150		0.152													
M4.5 x 0.75				4.01		4.04		4.07		4.10		4.15												
				4.60		4.09		4.12		4.15		4.20												
10-24		0.16	0.16		0.164		0.165		0.166		0.168													
		0.17	0.17		0.167		0.168		0.170		0.173													
10-32		0.170	0.170		0.171		0.172		0.173		0.174													
		0.172	0.173		0.174		0.175		0.176		0.177													
M5 x 0.80						4.48		4.51		4.54		4.57												
						4.53		4.56		4.59		4.62												
12-24		0.19	0.19		0.190		0.191		0.192		0.193		0.195				0.198							
		0.19	0.19		0.193		0.194		0.196		0.197		0.200				0.203							
M6 x 1.00						5.35		5.38		5.41		5.44		5.49										
						5.42		5.45		5.48		5.51		5.56										
M6.3 x 1.00						5.65		5.68		5.71		5.74		5.79	5.85									
						5.72		5.75		5.78		5.81		5.86	5.91									
1/4-20					0.218		0.218		0.219		0.221		0.224				0.227		0.228	0.230				
					0.220		0.221		0.223		0.225		0.228				0.231		0.233	0.235				
M7 x 1.00						6.35		6.40		6.45		6.50		6.55	6.63		6.71							
						6.42		6.47		6.52		6.57		6.62	6.70		6.78							
5/16-18						0.28		0.278		0.279		0.280					0.281		0.283	0.285				
						0.28		0.280		0.281		0.283					0.285		0.288	0.290				
M8 x 1.25								7.19		7.22		7.25		7.30	7.35		7.43			7.51				
								7.27		7.30		7.33		7.38	7.43		7.51			7.59				
3/8-16												0.335		0.336			0.337		0.337	0.342	0.344			
												0.337		0.338			0.340		0.340	0.346	0.349			
M10 x 1.50								9.03		9.08		9.13		9.18	9.26		9.34			9.42	9.50			
								9.12		9.17		9.22		9.27	9.35		9.43			9.51	9.59			
7/16-14													0.392				0.394		0.396	0.398	0.401	0.404		
													0.395				0.397		0.400	0.402	0.405	0.409		
M12 x 1.75										10.86		10.91		10.96	11.01		11.1			11.2	11.3	11.3		
										10.98		11.03		11.08	11.13		11.2			11.3	11.4	11.5		
1/2-13																	0.450		0.452	0.454	0.455	0.459		
																	0.453		0.455	0.457	0.460	0.464		

HOLE DIAMETER

(Continued on next page)

Extruded Holes



Suggested extruded holes in light-gauge steel for TAPTITE II® and DUO-TAPTITE® Screws & Bolts (Continued from page 11)

Approximate Material Thickness "T"												
IN MM	.024 - .035 0.61 - 0.89		.042 - .048 1.07 - 1.22		0.060 1.52		0.09 2.29		0.106 2.69		0.122 3.10	
	H	R	H	R	H	R	H	R	H	R	H	R
IN. 0.081 - .100 MM 2.06 - 2.54	0.040	0.005	0.040	0.005	0.040	0.006	0.043	0.010				
IN. .101 - .130 MM 2.57 - 3.30	0.047	0.005	0.047	0.005	0.047	0.006	0.052	0.010	0.054	0.010		
IN. .131 - .150 MM 3.33 - 3.81	0.053	0.005	0.053	0.005	0.053	0.006	0.060	0.010	0.063	0.010	0.072	0.013
IN. .151 - .180 MM 3.84 - 4.57			0.060	0.005	0.081	0.006	0.070	0.010	0.075	0.010	0.087	0.013
IN. .181 - .220 MM 4.60 - 5.59			0.070	0.005	0.070	0.006	0.090	0.010	0.095	0.010	0.104	0.013
IN. .221 - .260 MM 5.61 - 6.60					0.075	0.006	0.100	0.010	0.105	0.010	0.120	0.013
IN. .261 - .300 MM 6.63 - 7.62					0.083	0.006	0.116	0.010	0.125	0.010	0.140	0.013
IN. .301 - .340 MM 7.65 - 8.64							0.130	0.010	0.140	0.010	0.164	0.013
IN. .341 - .380 MM 8.66 - 9.65							0.140	0.010	0.155	0.010	0.170	0.013
IN. .381 - .430 MM 9.68 - 10.92							0.150	0.010	0.170	0.010	0.184	0.013

The above hole sizes are suggested starting points to be confirmed by actual testing. Extrusion Dimensions can vary due to tooling design and material being extruded.

Suggested hole sizes for Aluminum or Zinc die casting for TAPTITE II® and DUO-TAPTITE® Screws & Bolt

Screw Size	Hole Diameter as Cast Std. Taper				F Hole Dia. as Drilled	L Length of Thread Engagement	H Boss Dia.	J Distance to Edge for No Measurable Distortion
	Top A		Bottom B					
	Max.	Min.	Max.	Min.				
Metric Sizes (mm)								
M2 x 0.40	1.91	1.83	1.81	1.73	1.82	4.00	3.32	1.0
M2.5 x 0.45	2.39	2.31	2.28	2.20	2.29	5.00	4.15	1.2
M3 x 0.5	2.90	2.82	2.76	2.68	2.77	6.00	4.98	1.3
M3.5 x 0.6	3.31	3.23	3.21	3.13	3.23	7.00	5.81	1.6
M4 x 0.7	3.82	3.74	3.64	3.56	3.68	8.00	6.64	1.8
M4.5 x 0.75	4.31	4.23	4.11	4.03	4.16	9.00	7.47	2.0
M5 x 0.8	4.80	4.72	4.58	4.50	4.64	10.00	8.30	2.1
M6 x 1.0	5.74	5.66	5.48	5.40	5.54	12.00	9.96	2.6
M6.3 x 1.0	6.05	5.97	5.78	5.70	5.84	13.00	10.46	2.6
M7 x 1.0	6.78	6.70	6.48	6.40	6.54	14.00	11.62	2.6
M8 x 1.25	7.69	7.61	7.35	7.27	7.43	16.00	13.28	3.3
M10 x 1.5	9.64	9.56	9.22	9.14	9.32	20.00	16.60	3.9
M12 x 1.75	11.59	11.51	11.09	11.01	11.20	24.00	19.92	4.6
Inch Sizes (in)								
2-56	0.081	0.078	0.077	0.074	0.0779	0.172	0.197	0.046
3-48	0.093	0.090	0.088	0.085	0.0895	0.198	0.208	0.054
4-40	0.105	0.102	0.099	0.096	0.1006	0.224	0.220	0.065
5-40	0.118	0.115	0.112	0.109	0.1136	0.250	0.232	0.065
6-32	0.128	0.125	0.122	0.119	0.1238	0.276	0.242	0.081
8-32	0.155	0.152	0.148	0.145	0.1498	0.328	0.272	0.081
10-24	0.177	0.174	0.168	0.165	0.1710	0.380	0.315	0.108
10-32	0.182	0.179	0.174	0.171	0.1758	0.380	0.315	0.081
12-24	0.203	0.200	0.194	0.191	0.1970	0.432	0.359	0.108
1/4-20	0.235	0.232	0.224	0.221	0.2273	0.500	0.415	0.130
5/16-18	0.297	0.294	0.284	0.281	0.2872	0.625	0.519	0.144
3/8-16	0.359	0.356	0.343	0.340	0.3466	0.750	0.623	0.162
7/16-14	0.419	0.416	0.400	0.397	0.4050	0.875	0.726	0.186
1/2-13	0.481	0.478	0.460	0.457	0.4650	1.000	0.830	0.200

The minimum length of thread engagement should be equal to twice the diameter of the screw (to approach utilizing available screw strength). The hole diameter to ensure optimum performance, should provide for 65% to 75% thread engagement.

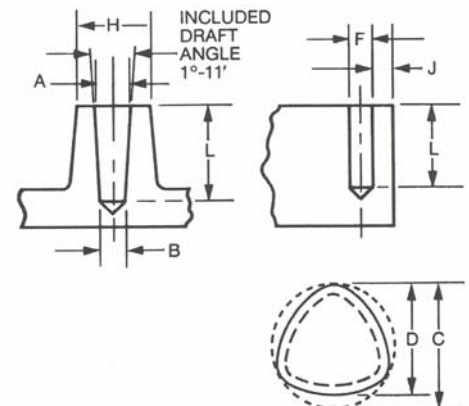

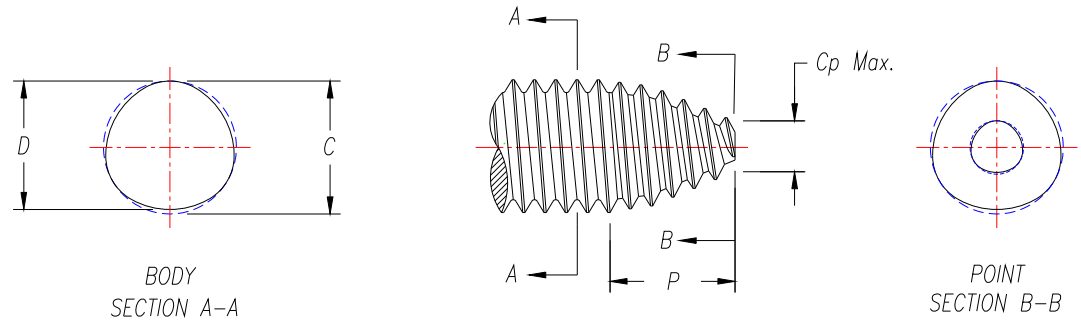

NON CUT-OFF STYLE POINT
(SHARP POINT OPTIONAL)

- Designed to resolve the fastening problems of 'stripping' and 'spin-out' in THIN SHEET METAL as is often found when using standard round-bodied sheet metal screws
- Increased torque performance in thin sheet metal applications
- Low end loads
- EXTRUDE-TITE® screws tend to drive straight
- Employs TRILOBULAR® technology in the joint
- Electrical grounding assured by the intimate contact of the roll-formed threads
- Reduces costs by allowing thinner, lighter materials in the assembly
- Reduces costs by reducing or eliminating repairs due to 'stripping', 'spin-outs', and off-angled entry of fastener on the assembly line
- Reduces costs by eliminating cleanup of chips, oil and debris caused by tapping operations
- Reduces costs by simplifying assembly – fewer components
- Reduces costs by simplifying assembly equipment

SCREW SIZE	SCREW BODY DIMENSIONS				POINT	
	Max.	C Min.	D Max.	Min.	Cp Maximum	Lp Maximum
Metric Sizes (mm)						
M2.5 x 0.45	2.57	2.48	2.52	2.44	0.94	2.48
M3.0 x 0.50	3.07	2.98	3.02	2.93	1.26	2.75
M3.5 x 0.60	3.58	3.48	3.52	3.42	1.41	3.30
M4.0 x 0.70	4.08	3.98	4.01	3.91	1.56	3.85
M4.5 x 0.75	4.59	4.48	4.51	4.41	1.89	4.13
M5.0 x 0.80	5.09	4.98	5.01	4.90	2.21	4.40
M6.0 x 1.00	6.10	5.97	6.00	5.87	2.51	5.50
M7.0 x 1.00	7.10	6.97	7.00	6.87	3.51	5.50
M8.0 x 1.25	8.13	7.97	8.01	7.85	3.64	6.88
M10 x 1.50	10.15	9.97	10.00	9.82	4.76	8.25
M12 x 1.75	12.18	11.97	12.00	11.80	5.89	9.63
Inch Sizes (in)						
3-48	0.1010	0.0970	0.0990	0.0950	0.026	0.115
4-40	0.1145	0.1105	0.1120	0.1080	0.024	0.138
5-40	0.1275	0.1235	0.1250	0.1210	0.037	0.138
6-32	0.1410	0.1350	0.1380	0.1320	0.028	0.172
8-32	0.1670	0.1610	0.1640	0.1580	0.054	0.172
10-24	0.1940	0.1880	0.1900	0.1840	0.044	0.229
10-32	0.1930	0.1870	0.1900	0.1840	0.080	0.172
12-24	0.2200	0.2140	0.2160	0.2100	0.070	0.229
1/4-20	0.2550	0.2490	0.2500	0.2440	0.076	0.275
5/16-18	0.3180	0.3120	0.3125	0.3065	0.119	0.306
3/8-16	0.3810	0.3750	0.3745	0.3685	0.158	0.344
7/16-14	0.4445	0.4385	0.4375	0.4315	0.190	0.393
1/2-13	0.5075	0.5015	0.5000	0.4940	0.233	0.423

Length Tolerances

Inch

Lengths up to and including 1" ± 0.030"
Lengths greater than 1" ± 0.050"

Metric

Lengths up to & including 25mm ± 0.8mm
Lengths greater than 25mm ± 1.3mm

EXTRUDE-TITE® Fasteners



- First prevailing-off torque is an indication of locking torque and resistance to vibrational loosening and was judged favorably high for EXTRUDE-TITE® screws in thin sheet metal.
- Performance in extruded holes is slightly higher than in drilled holes. Therefore, either hole design is favorable.
- EXTRUDE-TITE® screws typically screw forward and backward extrude material beyond its original thickness, providing the fastener with over twice the engagement than that of non-extruded materials.
- An important consideration is the significantly superior and consistent strip-to-drive ratio of EXTRUDE-TITE® screws over other sheet metal screws which allows for more liberal driver clutch settings at the fastening site.
- Tests have shown that EXTRUDE-TITE® fasteners may be used in a wide range of pilot hole sizes with satisfactory results depending upon application requirements.
- May be used in thicker materials as a thread-forming, locating point fastener.
- Couple EXTRUDE-TITE® fasteners with an underhead locking feature for ultimate vibrational and 'spin-out' resistance or with a sharp point to pierce cloth, vinyl or other such similar materials.

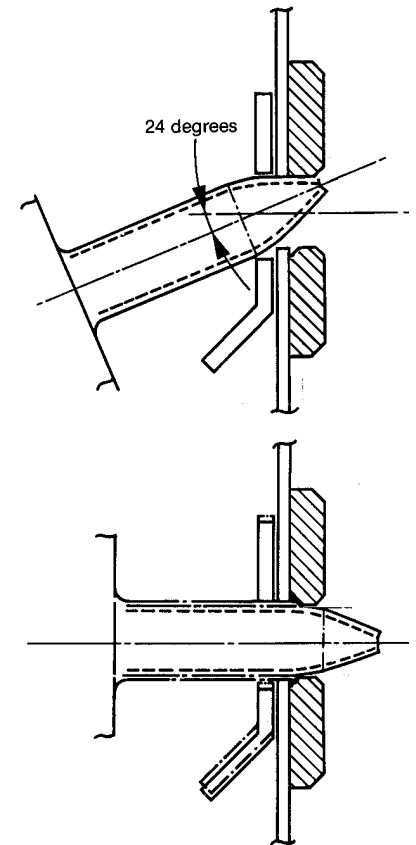

Self-aligning point feature 'finds' the holes, lines them up and fastens them in one operation.

Description	Material Thickness	Hole Size	Drive Torque	First Prevailing Off Torque	Strip Torque	Strip to Drive Ratio	Recommended Tightening Torque
#6 - 32 x 3/8 Hex Washer Head	0.028	0.080	4	2	12	3:1	8
	0.032	0.080	5	3	15	3:1	10
	Zinc & Wax 0.040	0.080	7	3	21	3:1	14
#8 - 32 x 3/8 Hex Washer Head	0.028	0.110	5	2	15	3:1	10
	0.032	0.110	6	3	18	3:1	12
	Zinc & Wax 0.040	0.110	10	4	26	2.6:1	18
#10 - 32 x 9/16 Hex Washer Head	0.028	0.138	8	3	25	3:1	17
	0.032	0.138	10	4	29	3:1	20
	Zinc & Wax 0.040	0.138	15	11	45	3:1	30
1/4 - 20 x 5/8 Hex Washer Head	0.028	0.181	12	6	35	3:1	24
	0.032	0.181	14	7	36	2.6:1	25
	Zinc & Wax 0.040	0.181	21	10	57	2.7:1	39
M4 x 0.7 x 13 Hex Washer Head	0.70	2.64	0.90	0.32	2.18	2.4:1	1.54
	0.80	2.64	1.13	0.39	2.35	2:1	1.74
	Zinc & Wax 1.00	2.64	1.32	0.52	2.71	2:1	2.02
M5 x 0.8 x 16 Hex Washer Head	0.70	3.45	0.93	0.35	2.59	2.8:1	1.76
	0.80	3.45	1.11	0.73	3.55	3:1	2.33
	Zinc & Wax 1.00	3.45	1.66	1.40	4.82	3:1	3.24
M6 x 1.0 x 16 Hex Washer Head	0.70	4.60	1.09	0.48	3.71	3.4:1	2.40
	0.80	4.60	1.32	0.52	3.79	3:1	2.56
	Zinc & Wax 1.00	4.60	2.12	0.92	6.17	3:1	4.15

TEST PARAMETERS -

- Test material: cold-rolled draw quality aluminum killed steel plate hardened to Rb 50-55
- Test washer: .063 thick steel
- Clearance hole: .180(#6), .200(#8), .220(#10), .280(1/4")
- Drive speed: 250 RPM under load

- These values may vary proportionately to application. Smaller hole sizes for example, will increase drive, first off, strip torques, etc. Material thickness will also effect torque/tension values as indicated in the table. These values were derived from averages of over 1800 laboratory tests under specific conditions. These values are to be used only as a guide since actual application performance results may vary.



POWERLOK[®] All Metal Locking Screws

FOR BETTER FASTENING AT LOWEST IN-PLACE COST

- Enhanced locking ability
- Continuous locking action
- Resistant to high temperatures
- Reusable
- No special taps

Enhanced locking ability

"POWERLOK[®], TRILOBULAR[®] self locking screws are a unique concept in locking screws." Made from high strength steel, hardened and tempered to an optimum strength-toughness serviceability, the POWERLOK[®] screw achieves enhanced locking ability through the combination of a novel 60°-30° thread form and a TRILOBULAR[®] thread body section. A significant mechanical advantage of this design is that the locking action is developed at the outermost radius of the torque arm of the screw body, whereas other locking screws develop their effective resistance at lesser radius points on thread flanks, down even to the thread root surface. The deeper geometry of the POWERLOK[®] thread, along with a slight increase in the thread major diameter over equivalent size machine screw, adds to the effective stripping resistance of the fastener. In addition, the centralization of the POWERLOK[®] lobes in the nut member thread allows the 30° thread crest on the fastener to flex elastically under clamp load, simulating the live action of spring washers.

Continuous locking action

POWERLOK[®] screws do not have to be seated to lock, as the locking thread feature extends the entire length of the fastener. They resist vibration at any point along their body length. POWERLOK[®] fasteners are excellent adjusting screws. The locking action is instantaneous and, unlike chemical locking agents, no reaction or curing time is required.

Resistant to high temperatures

POWERLOK[®] screws do not lose their action or efficiency in high temperature environments. Non-metallic additives featured with many lock screws lose much or all of their developed force or deteriorate with time under the influence of temperatures of 200°F or higher. POWERLOK[®], being an all-metal locking fastener, is unaffected by these or higher operating temperatures.

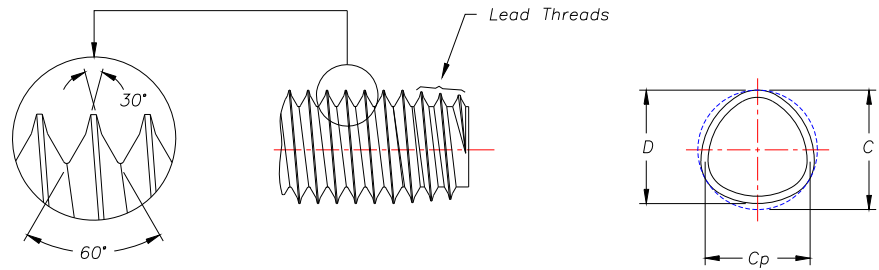

Thread Form Profile

POWERLOK[®] - Metric Standards

NOMINAL SIZE OF SCREW	DIMENSIONS THREAD BODY (millimeters)			
	DIAMETER OF CIRCUMSCRIBING CIRCLE C		MEASUREMENT ACROSS CENTER D	
	MAX.	MIN.	MAX.	MIN.
M3.5 x .6	3.69	3.59	3.57	3.47
M4 x .7	4.22	4.10	4.08	3.96
M5 x .8	5.26	5.13	5.10	4.97
M6 x 1	6.30	6.15	6.10	5.95
M8 x 1.25	8.35	8.20	8.10	7.95
M10 x 1.5	10.40	10.25	10.10	9.95
M12 x 1.75	12.45	12.30	12.10	11.95

POWERLOK[®] - Inch Standards

NOMINAL SIZE OF SCREW	DIMENSIONS THREAD BODY (inches)			
	DIAMETER OF CIRCUMSCRIBING CIRCLE C		MEASUREMENT ACROSS CENTER D	
	MAX.	MIN.	MAX.	MIN.
4-40	0.1170	0.1120	0.1120	0.1070
5-40	0.1310	0.1250	0.1260	0.1200
6-32	0.1470	0.1410	0.1410	0.1350
8-32	0.1725	0.1665	0.1665	0.1605
10-24	0.2050	0.1980	0.1970	0.1900
10-32	0.1995	0.1925	0.1935	0.1865
12-24	0.2310	0.2240	0.2230	0.2160
1/4-20	0.2695	0.2615	0.2595	0.2515
5/16-18	0.3315	0.3235	0.3205	0.3125
3/8-16	0.3945	0.3865	0.3820	0.3740
7/16-14	0.4595	0.4515	0.4455	0.4375
1/2-13	0.5235	0.5155	0.5080	0.5000

Length Tolerance - Inch - Per ANSI B18.6.3

Nominal Screw Length	Nominal Screw Size	
	#4-#12	1/4"-1/2"
	Tolerance on Length	
To 1/2" Inclusive	+0, -.020	+0, -.030
Over 1/2" to 1" Inclusive	+0, -.030	+0, -.030
Over 1" to 2" Inclusive	+0, -.060	+0, -.060
Over 2"	+0, -.090	+0, -.090

Length Tolerance

Metric per ANSI B18.6.7M Nominal Screw Length
to 3mm incl.
over 3 to 10mm
over 10 to 16mm
over 16 to 50mm
over 50mm

Exceed IFI locking screw standards Have locking action you can't wear out!

Reusable - Subjecting the POWERLOK[®] screw to increasing clamp load results in continuously increasing thread flank contact so that unit pressure between mating surfaces tends to remain constant, an important factor in diminishing galling and abrasion. Together with the burnishing action of the TRILOBULAR[®] crests means continued locking effectiveness, after repeated insertions and removals.

Locking performance - Will meet or exceed IFI 124 (inch) or IFI 524 (metric) Specifications for Prevailing Torque Locking Screws. Transverse vibration test data available upon request. Actual performance will vary depending on effective finish lubricity and nut condition.

No special taps - You save time and money by using a regular nut or Class 2B (6G) tapped hole. POWERLOK[®] is precision made - so the hole thread doesn't have to be.

Applications - Widely used in automotive and other mass-assembly operations. You can use POWERLOK[®] screws wherever you need reliable vibration resistance, continued high performance, despite repeated assembly/disassembly using normal tapped holes. They can be used in pre-tapped holes in ductile metals.

STANDARD MATERIAL - Depending on part size, low carbon, medium carbon or alloy steel is selected. Then the steel is hardened and tempered to the optimum combination of tensile strength and toughness. Tensile or torsional strength can be more than twice that of machine screws. Screws can be made in strength levels to suit a wide range of application requirements. Property Class 10.9 is often preferred. Finishes can be supplied as required.

KLEERLOK[®] Thread Clearing Lock Screw

The KLEERLOK[®] feature is designed to be used in conjunction with TRILOBULAR[®] fasteners in pre-tapped holes which may be contaminated with weld splatter, paint, primer or other foreign matter.

The KLEERLOK[®] feature can be combined on a POWERLOK[®] screw for paint clearing and locking torque or on a reduced diameter TAPTITE[®] screw as a version for joints where classical torque-tension fastening rather than a locking screw is desired.

KLEERLOK[®] Point Form

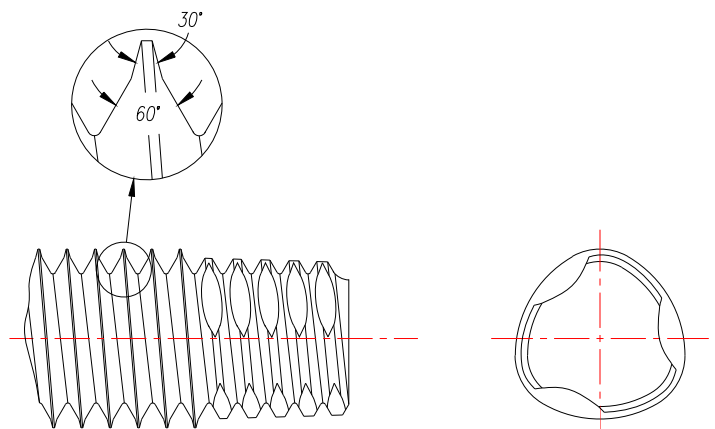

The PLASTITE® family of TRILOBULAR® screws for fastening in plastic

The following is intended as a guide to choosing threaded fasteners which will provide optimum application and performance characteristics in a wide range of plastics. It contains detailed information on PLASTITE® thread-rolling screws.

Because of the variations in the manufacture of individual grades of plastics, particularly in the quantity of filler used, it is imperative that tests be conducted on each proposed application by a competent engineering laboratory.

REMINC/CONTI's network of licensees provide this testing service usually without obligation. This provides the design engineer with recommendations in the following areas: type of fasteners, quantity and sizes, design of the fastening site or boss, hole sizes. Torque values needed for power tool settings during assembly, including: drive, strip, seating, breakaway and prevailing off torque. A written report on the test results is usually provided.

How the TRILOBULAR® family optimizes fastener performance and lowers in-place costs.

PLASTITE® TRILOBULAR® thread-rolling screws were developed specifically for use in plastics. They combine a unique TRILOBULAR® cross-sectional form with deep, wide, spaced threads.

Easier to drive. Three swaging lobes with full relief of the thread form reduce driving effort and operator fatigue.

More holding power. The three-lobed design of PLASTITE® screws takes full advantage of the cold flow characteristics of many plastics by allowing plastic material to recover and fill in between the lobes. This establishes maximum resistance to vibrational loosening. In addition, the screws' deep, coarsely spaced threads provide a heavier shear area and deeper thread engagement in the plastic, further enhancing holding capabilities.

Reduced hoop stress. The PLASTITE® screw's TRILOBULAR® design reduces dangerous hoop stress and the friction of root interference, which can frequently cause the bursting of thin-walled bosses.

Better quality threads. The smooth burnishing action of PLASTITE® thread-rolling screws eliminates the dangers inherent in the use of thread-cutting screws. PLASTITE® screws roll form high quality internal threads with no damage to the molecular structure of the plastic, significantly reducing the danger of material failure.

Fast, cost-effective application. The easy starting, easy driving capabilities of PLASTITE® screws cut assembly time and costs. Exceptional holding power eliminates the need for costly inserts and lockwashers.

Fewer torque problems. The unusually high drive-to-strip ratio of PLASTITE® screws permits a wider span of torque settings to be safely used with automatic drivers. Strip out is virtually eliminated.

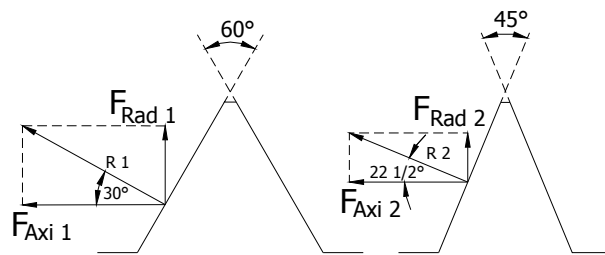

Resolution of Resultant Forces comparing PLASTITE® 45 thread form with standard 60 thread form.

PLASTITE® 45 Screws

PLASTITE® 45 screws represent the latest refinement of the cost savings and performance capabilities of TRILOBULAR® technology for assembling plastic components. The TRILOBULAR® shape makes use of the plastic's natural resiliency and creep characteristics, allowing the plastic to fill in the depressions between the lobes. This helps lock the fastener in place providing prevailing torque if fastener removal is attempted. Years of research revealed that exceptional performance could be achieved by combining the TRILOBULAR® shape with the following attributes:

- Wide thread spacing
- Narrow thread angle

The extra wide thread spacing and more acute thread angle of PLASTITE® 45 screws keep induced stress to a minimum during the thread forming operation. These attributes also permit a deeper thread without increased drive torque. Also, the extra wide thread spacing allows stress to be dispersed over a greater area in the plastic boss or nut member, and the plastic material remaining between the threads is left strong and intact, thus providing for high assembly loads and stripping resistance. The narrow thread angle also reduces stress by displacing less material

and creating less bursting pressure (See above illustration).

Hardened and tempered screws are significantly stronger than plastic so if the assembly becomes over-torqued, usually the plastic will give way and strip out. Strip out in the plastic will occur cylindrically so the more nut member material that remains within the cylinder the more resistant to strip out will be the plastic. It is for this reason the wide thread spacing of a PLASTITE® 45 screw increases the assembly strength at the same time that it reduces stress.

PLASTITE® 45 screws are the perfect balance between application needs and efficient manufacturing for consistent performance.

PLASTITE® 48-2 Screws

PLASTITE® 48-2 screws have a TRILOBULAR® body like PLASTITE® 45 screws, but incorporate a double lead, two-start thread. The steeper helix angle from the double lead permits higher fail torque to be obtained, usually resulting in a higher differential between fail torque and thread forming torque, which allows for easier power tool adjustment when assembly stripping is the problem.

PLASTITE® 45 Screws



Recommended pilot hole sizes are subject to variation dependent on depth of engagement, ease of driving required and material being tapped. Users of PLASTITE® 45 screws should perform their own test to determine the most efficient pilot hole size for their own particular use, or contact the application engineering department of a licensed supplier or REMINC/CONTI.

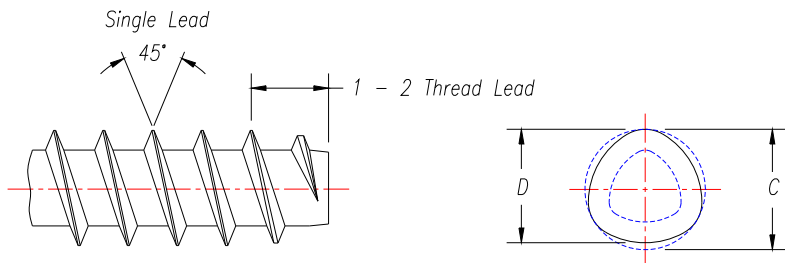

MATERIAL:	LENGTH TOLERANCES:	
SAE Low Carbon	Inch	Metric
Steel, Suitably Hardened and Tempered	Sizes #2 - #12 thru 3/4" ± .030"	Sizes M2 - M5 Up to 20mm ± 0.8 mm
	Sizes #2 - #12 over 3/4" ± .050"	Sizes M2 - M5 Over 20mm ± 1.3mm
Finish: As Requested	Sizes Over 1/4" Dia. All Lengths ± .050"	Sizes M6 - M8 All Lengths ± 1.3mm

PLASTITE® 45 Standards - METRIC

Screw Size	"C"	"D"	Minimum Out-of-Round	Recommended Pilot Hole	
				Min.	Max.
M2 x 1.35	2.04 - 1.92	1.99 - 1.87	0.05	1.40	1.60
M2.5 x 1.4	2.53 - 2.41	2.49 - 2.37	0.05	1.85	2.05
M3 x 1.5	3.04 - 2.92	2.99 - 2.87	0.05	2.30	2.50
M3.5 x 1.65	3.54 - 3.42	3.46 - 3.34	0.08	2.75	3.00
M4 x 1.75	4.04 - 3.89	3.94 - 3.79	0.10	3.20	3.45
M4.5 x 2	4.54 - 4.39	4.43 - 4.28	0.11	3.60	3.90
M5 x 2.2	5.04 - 4.89	4.94 - 4.79	0.10	3.70	4.10
M5 x 2.3	5.04 - 4.89	4.94 - 4.79	0.10	3.70	4.10
M6 x 2.5	6.04 - 5.89	5.93 - 5.78	0.11	4.70	5.10
M8 x 3	8.04 - 7.86	7.89 - 7.71	0.15	6.50	7.10

PLASTITE® 45 Standards - INCH

Screw Size	"C"	"D"	Minimum Out-of-Round	Recommended Pilot Hole	
				Min.	Max.
#2-19	.0875-.0835"	.0845-.0805"	.002"	.065"	.073"
#3-18	.101-.097"	.098-.094"	.002"	.076"	.084"
#4-17	.1145-.1095"	.111-.106"	.0025"	.087"	.096"
#5-15	.1275-.1225"	.1235-.1185"	.003"	.099"	.108"
#6-13	.141-.136"	.137-.132"	.003"	.102"	.114"
#7-12	.153-.148"	.1485-.1435"	.0035"	.114"	.127"
#8-11	.167-.161"	.162-.156"	.004"	.126"	.139"
#9-10	.179-.173"	.174-.168"	.004"	.135"	.149"
#10-9	.194-.188"	.189-.183"	.004"	.150"	.165"
#12-9	.220-.214"	.2145-.2085"	.0045"	.170"	.186"
1/4-8	.253-.247"	.247-.241"	.005"	.198"	.216"
9/32-8	.284-.278"	.278-.272"	.005"	.227"	.246"
5/16-8	.316-.308"	.309-.301"	.006"	.255"	.275"
21/64-8	.332-.324"	.325-.317"	.006"	.270"	.290"
11/32-8	.349-.341"	.342-.334"	.006"	.285"	.306"
3/8-7	.379-.371"	.371-.363"	.007"	.309"	.332"

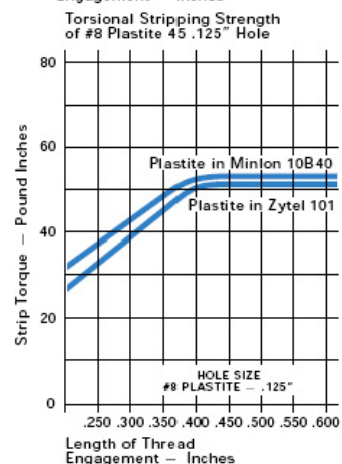
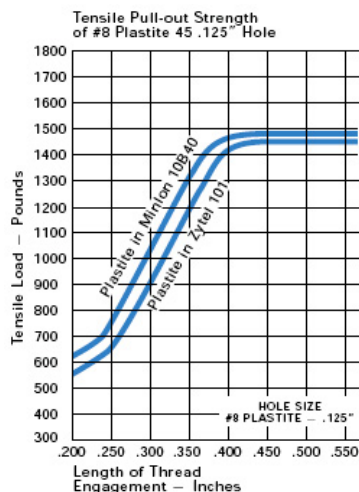
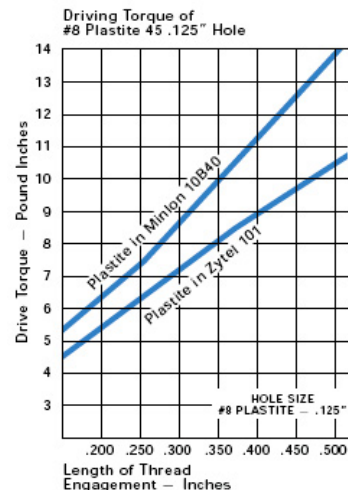

PLASTITE® 48-2 TRILOBULAR® thread-rolling screws have twin lead threads to provide faster, more efficient insertion. The sharp 48° thread profile increases holding strength and reduces material displacement and boss bursting tendencies. Drive and strip torques are higher, making drive tool adjustments simple. NOTE: Component and boss design should allow for much faster engagement than with single lead screws.

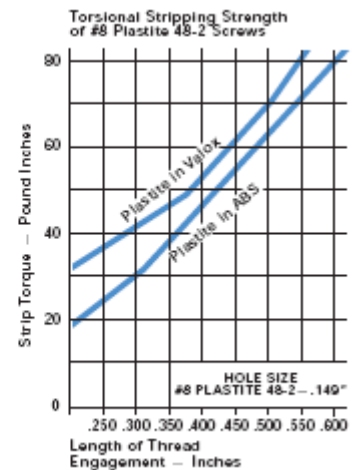
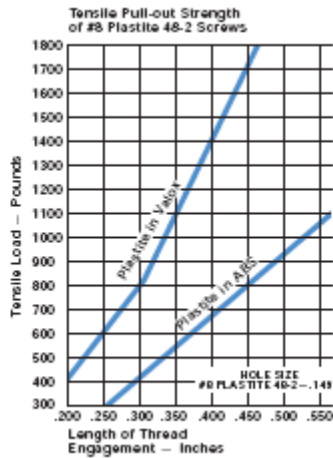
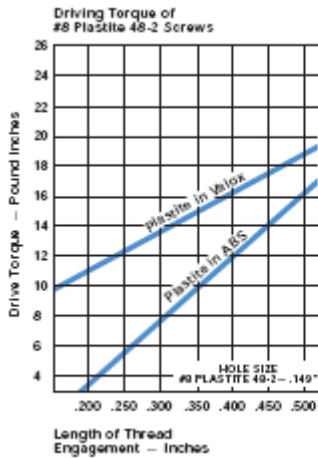
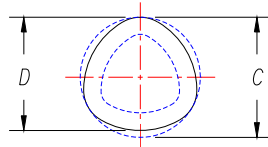
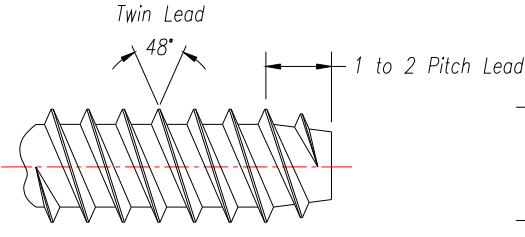

MATERIAL:

Low Carbon Steel, Suitably Hardened and Tempered

FINISH:

As Requested

LENGTH TOLERANCES

Nom.

Length

Thru 3/4"

Over 3/4"

Over 1/4" Dia.

All Lengths

Tol.

± .030"

± .050"

± .050"

Screw Size T.P.I. (1)	"C"		"D"		Minimum Out-of- Round	Recommended Pilot Hole Sizes	
	Max.	Min.	Max.	Min.		Soft Ductile Materials	Brittle Materials
2 (.089) - 28	.092	.086	.089	.083	.002	.076	.080
* 3 (.106) - 24	.110	.104	.106	.100	.002	.088	.094
4 (.123) - 20	.127	.121	.123	.117	.002	.100	.106
6 (.143) - 19	.147	.141	.143	.137	.003	.122	.128
* 7 (.160) - 18	.166	.160	.160	.154	.004	.134	.142
8 (.179) - 16	.185	.179	.179	.173	.004	.149	.158
* 9 (.193) - 15	.199	.193	.193	.187	.004	.162	.172
10 (.208) - 14	.212	.206	.208	.202	.004	.175	.185
* 12 (.226) - 14	.232	.226	.226	.220	.005	.195	.205
1/4 (.268) - 10	.276	.270	.268	.262	.006	.224	.240
5/16 (.335) - 9	.345	.335	.335	.325	.006	.286	.303

* Non-standard size

1. Size/TPI – The PLASTITE® 48-2 screw size designation combines the commonly used numerical screw size with the major diameter (Max. "D") as measured with ordinary micrometers, followed by the number of threads per inch.

2. Recommended pilot hole sizes are subject to variation dependent on depth of engagement, ease of driving required and material being tapped. Users of PLASTITE® 48-2 screws should perform their own test to determine the most

efficient pilot hole size for their own particular use, or contact the application engineering department of a qualified supplier or REMINC/CONTI.

PUSHTITE® II Fasteners



PUSHTITE® II TRILOBULAR® fasteners Threads are helical, not annular, are designed to be pressed into permitting displaced air to escape recommended hole sizes with a single, during insertion. straight-line stroke. They can be used in a broad range of thermoplastics of widely varying densities.

The helical thread form also allows the fasteners to be removed and reinserted if necessary.

PUSHTITE® II fasteners combine a 3 lobe thread form with a 70°-10° semi-buttress thread shape to permit easy entry and provide exceptional pullout resistance.

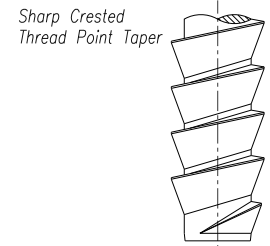

Sharp Crested Thread Point Taper
Helical, Semi-Buttress 70°-10° Thread Profile

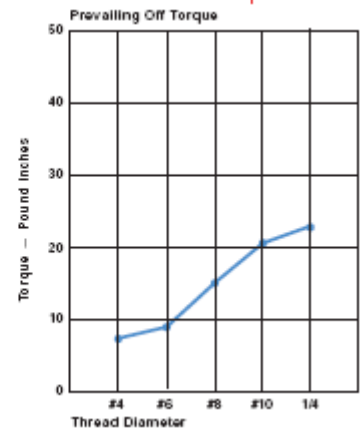
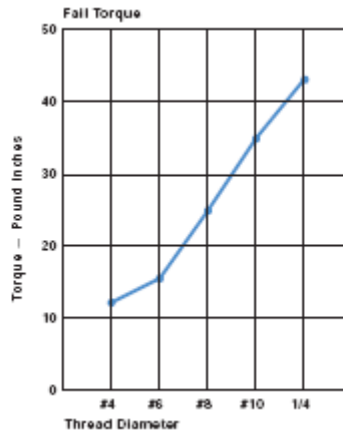
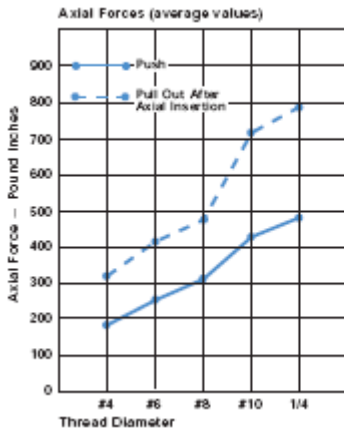
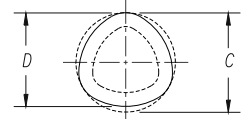

Screw Size T.P.I.	"C"		"D"		"P" Point Diameter Ref.	Minimum Out-of- Round	Pilot Hole Diameter
	Max.	Min.	Max.	Min.			
2-22	.0885	.0835	.0850	.0800	0.063	.0035	.079-.073
3-20	.1020	.0970	.0980	.0930	0.073	.0040	.092-.085
4-18	.1155	.1105	.1105	.1055	0.083	.0045	.105-.097
6-16	.1410	.1350	.1360	.1300	0.104	.0050	.128-.120
7-15	.1520	.1460	.1465	.1405	0.112	.0550	.139-.131
8-14	.1680	.1620	.1620	.1560	0.124	.0060	.152-.144
9-13	.1810	.1750	.1740	.1680	0.134	.0070	.165-.156
10-12	.1940	.1880	.1850	.1790	0.143	.0090	.175-.165
12-11	.2200	.2140	.2100	.2040	0.164	.0100	.201-.191
1/4-9	.2550	.2490	.2440	.2390	0.182	.0110	.229-.217

MATERIAL:

Low Carbon Steel, Suitably Hardened and Tempered

FINISH:

As Requested

LENGTH TOLERANCES

Nom.

Length	Tol.
Thru 3/4"	± .030"
Over 3/4"	± .050"
Over 1/4" Dia.	
All Lengths	± .050"

Recommended length of thread engagement is two screw diameters minimum. **Tamper Resistant yet Removable for Service.**

The range of suggested hole sizes is large because of the range of densities in thermoplastic compounds and length of thread engagements. Generally low density plastic can use smaller hole diameters. Long length of engagement (2.5 to 3 diameters) require larger holes.

PUSHTITE® II fasteners are normally available with a drive system in the head for removal, adjustment or final tightening. Where adjustment or removal is not required they are available without slot, recess or socket in the head.

Performance in graphs is based on the average of several tests in different materials.

THE TOUGHER THREAD ROLLING SCREWS

CORFLEX® - EXPANDS THE COST SAVINGS HORIZON

TAPTITE II®, TAPTITE® CA and DUO-TAPTITE® screws are capable of performing in large diameter sizes in deep thread engagements. The past limitation in exploiting the in-place cost savings of large size TRILOBULAR® products was that the required screw hardness was achieved through case hardening. Case hardening is detrimental to structural applications as the fastener would be susceptible to differing modes of "brittle" failure.

Tougher! That's the whole reason why CORFLEX® fasteners were invented!

Screws come in many different strengths; ordinary machine screws are manufactured from non-hardened, low-carbon steel.

Regular tapping screws are manufactured from low-carbon steel case hardened to 107 ksi minimum strength.

Metric Grade 9.8 or inch Grade 5 machine screws are manufactured to 930 MPA and 120 ksi minimum respectively. They are manufactured from low to medium carbon alloy or boron intensified steel.

Metric Grade 10.9 or inch Grade 8 machine screws are manufactured from medium carbon alloy steel to 1040 MPA and 150 ksi strength respectively.

Prior to CORFLEX®-'I' technology, there was no thread-forming or thread-rolling fastener with both the thread forming hardness of a tapping screw and the toughness of a grade strength machine screw!

CORFLEX®-'I', TAPTITE II®, TAPTITE® CA and DUO-TAPTITE® screws and bolts are unique. They are manufactured from 4037 alloy steel and custom heat treated throughout to whatever strength is required! This could be Grade 8.8, 9.8, 10.9, 12.9 or anything in between!

CORFLEX®-'N' screws are neutral hardened so the bolt or screw has uniform structure similar to grade strength machine screws. Then, after bolt strength is heat treated to the required properties of the application, the thread rolling zone is induction hardened for thread forming capability. This selective zone heat treating is done on customized automatic feed induction hardening machines.

It is this two stage heat treatment that makes the CORFLEX®-'I' version TAPTITE II®, TAPTITE® CA and DUO-TAPTITE® screws unique; strong and tough in the load bearing areas but very hard in the thread rolling area.

The combination of strength and toughness enables, the CORFLEX®-'I' screw to bend without breaking and withstand alternating or cyclical loads. Tension can be applied and relaxed almost indefinitely without encouraging fatigue cracking.

CORFLEX®-'N' versions of TAPTITE II®, TAPTITE® CA and DUO-TAPTITE® screws are neutral hardened and tempered to desired strength or grade level. A subsequent zone hardening of the thread rolling point is not necessary as the intended use of CORFLEX®-'N' screws and bolts is in soft ductile non-ferrous materials, such as zinc and aluminum. Additionally, POWERLOK® screws are heat treated to CORFLEX®-'N' Metallurgy.

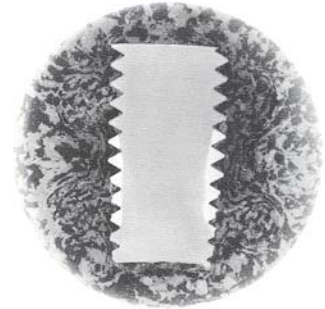

HEAT TAILORED FOR EXTRA RUGGEDNESS

Pin-point precision of high hardness zone in axial section of CORFLEX®-'I' TAPTITE II® screw is shown by crescent shaped area in chemically etched mounts.



"Punishment Proved" Performance: The unusual tapping and fastening capabilities of the CORFLEX®-'I' screw are illustrated by this test. A 1/2-13 diameter CORFLEX®-'I' screw withstands a 25° body bend after having formed an internal thread with a 95% engagement in a section of 5/8" thickness of cold rolled steel.

CAN ANY OTHER SELF-THREADING SCREW DO AS MUCH?



Above is an illustration of the excellent thread forming capability of a CORFLEX®-'I' TAPTITE II® bolt in producing deep threads of one diameter length or greater in heavy (multiple punch) extrusions as required for structural applications.

General Information



Head Dimensions: All TRILOBULAR® screws and bolts can be provided with any standard head style, to ISO, ANSI or any other international standard.

Lengths: TAPTITE II®, DUO-TAPTITE® and POWERLOK® screws and bolts are manufactured to applicable local standards on thread length and screw length. Tolerances listed in brochure are suggested only. Due to the greater manufacturing variation in producing gimlet pointed screws, EXTRUDE-TITE® and TAPTITE® CA screws are manufactured to tolerancing as stated on Page 13. PLASTITE® and PUSH TITE® II screws are manufactured to length tolerances as stated on Pages 18-20.

Available Sizes: Sizes listed are the most popular standard sizes. TRILOBULAR® products can be supplied in standard miniature screw and large bolt sizes not listed. Special size/pitch combinations are also available.

Materials: TRILOBULAR® screws and bolts are manufactured from low to medium carbon steel in the case hardened version and from various grades of alloy steel to meet the grade strength requirements of CORFLEX®-I selective hardened version.

Metallurgy: TAPTITE II® screws are supplied in two metallurgical categories; case hardened or selective hardened to REMINC/CONTI CORFLEX® grade strength levels. Applicable standards would include SAE-J81 for inch screws and SAE-J1237 for metric. TAPTITE II® CORFLEX®-I screws can be supplied to metric grades equivalent to 8.8, 10.9 and 12.9 and inch Grades 8 and 5 or to special hardness and toughness requirements.

Case hardened fasteners are not recommended for use in die cast or extruded aluminum or zinc particularly when galvanic conditions, severe load or thermal cycling is present. CORFLEX®-I or CORFLEX®-N are recommended for these conditions.

POWERLOK® screws are manufactured to metric Grade 10.9 or inch Grade 8. POWERLOK® screws can be provided as case hardened but are not recommended unless used in a light duty application.

All TRILOBULAR® products can be produced in various stainless steel grades or from non-ferrous materials. (Stainless steel and non-ferrous product have limitations on thread forming capabilities.)

Finish: TRILOBULAR® screws and bolts can be supplied with all commercially available finishes and coatings. Electroplated finishes should be avoided on high strength grades. The addition of a wax lubricant is recommended on high surface friction finishes such as zinc. Electroplated fasteners should be baked.

Options: All TRILOBULAR® products can be supplied with several optional configurations, i.e. with shoulders, dog points, and with washer assembly. TAPTITE II® screws can be supplied with optional captive point or with "CA" gimlet point (see Page 5).

Optional Extras: Tables in this brochure cover only the standard, thread configurations and point styles available on TAPTITE II® / DUO-TAPTITE® CORFLEX® parts. Many variations are possible including:

- Sems versions with captive washers. Extra large heads and/or underhead collars to suit individual needs.
- Underhead earthing nibs to ensure earth continuity through painted surfaces;
- Unrolled root diameter dog points to assist location;
- Unrolled pitch-diameter 'captive' dog points for extra security;
- Partly threaded shanks for captive screws in cover plates;
- Security drive systems for tamper resistance.

Performance: TAPTITE II® and DUO-TAPTITE® screws in either case hardened or CORFLEX® version meet or exceed the performance requirements of SAE-J81, J1237, DIN 7500, GM 6171M, GM6202M, Ford WD-951 and 952, Ford ES-20003-S100 as well as several other automotive, OEM, and industrial specifications. POWERLOK® screws meet the performance requirements of IFI-124 and 524.

The following are aids to assist on the use of TAPTITE II® and DUO-TAPTITE® fasteners.

Percent thread chart	Page 8
Pilot hole sizes	Page 9
Typical torque performance	Page 10
Typical single punch	
extruded holes	Pages 11 & 12
Die cast cored holes	Page 12
CORFLEX®	Page 21

INSPECTION PROCEDURE:

TRILOBULAR® products can be checked with standard micrometers for D and 60° vee-anvil micrometers for C. Alternatively, C may be gauged using plain-hole ring gauges. These must have accurate holes as tabled for minimum and as tabled plus .025mm (.001 inch) for maximum.

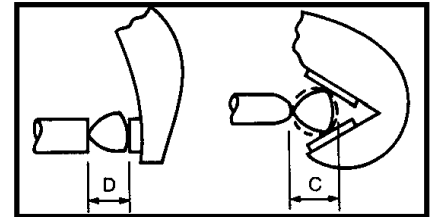

DISCLAIMER CLAUSE

The values shown are for guidance only. They are not to be used for design criteria. Their use and reliance thereon for any purpose by anyone is entirely voluntary and at the sole risk of the user. REMINC/CONTI is not responsible for any loss, claim, or damage resulting from their use. Consult our application engineers or the application engineering department of one of our many qualified producers for your specific application data.

ORDERING/SUPPLY:

When ordering from qualified TRILOBULAR® producers, be sure in all cases to specify thread size, nominal length, head and point style, whether it is TAPTITE II® or DUO-TAPTITE® etc., strength grade if CORFLEX®-N or CORFLEX®-I is involved, any other special features required, finish and quantity.

TECHNICAL ASSISTANCE:

This brochure contains basic information needed to achieve the cost savings potential of TRILOBULAR® fasteners.

To obtain further assistance and a list of qualified manufacturers, contact REMINC at (401) 841-8880 or e-mail reminc@reminc.net for North America or CONTI at +41(0)41/761 5822 or e-mail conti@contifasteners.ch.

RS Technologies Fastener Test Equipment

Measures torque and tension vs. angle, combined with electronic data acquisition.



Tukon Micro-Hardness Tester

Provided micro-hardness and micro-structure analysis



Junkers Design Transverse Vibration Tester

Simulates accelerated service conditions to predict joint integrity.

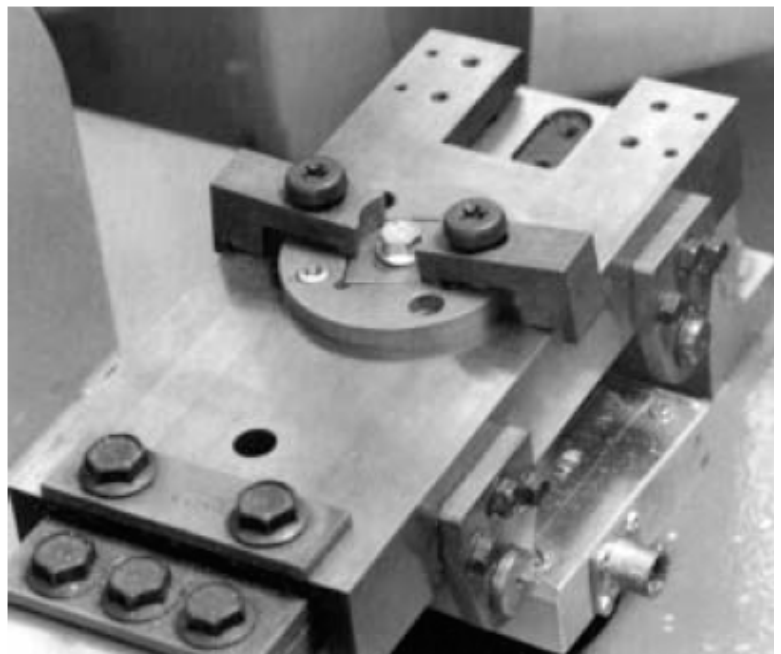

REMINC/CONTI

Research Engineering & Manufacturing Inc. (REMINC) and Conti Fasteners AG (CONTI) have successfully marketed TAPTITE® fastener technology internationally since 1961. Their success has been accomplished by licensing and training leading fastener producers worldwide.

The technical program in the United States is under the direction of REMINC, located in Middletown, Rhode Island and in other countries under the direction of CONTI, situated in Baar, Switzerland.

Although REMINC and CONTI are separate corporations and operate independently, each is dependent on the other for certain functional activities.

SERVICES

A summary of the capabilities of REMINC/CONTI in support of manufacturers:

Technical Support

- New Product Development
- Research and Development Reports
- Technical Manuals
- Technical Reports
- Technical Information Updates
- Engineering Consultation
- Computer Aided Design and Analysis
- Engineering Training
- Tooling Design and Procurement
- Manufacturing Guidance
- Manufacturing Cost Reduction
- Metallurgical Analysis
- End-User Application Guidance
- Technical Training Seminars

MARKETING SUPPORT

- Application Definition
- Application Reports
- Performance Documentation
- Sales Seminars
- Audio/Video Materials
- Graphics
- Customer Product Brochures
- Technical Liaison
- Joint Customer Visits
- Cooperative Studies
- Trademark and Patent Use

In addition to the above stated detail, REMINC/CONTI are positioned to provide:

- Contract Testing
- Contract Engineering
- Contract Consultation Activities
- Contract Joint Analysis
- Fastener Engineering Training

TAPTITE®, TAPTITE II®, TRILOBULAR®, DUO-TAPTITE®, EXTRUDE-TITE®, TAPTITE® CA, POWERLOK®, KLEERLOK®, PLASTITE® 45, PLASTITE® 48-2, PUSHITITE® II, THE CONTROLLABLE PRODUCT™, CORFLEX®, CORFLEX®-I', CORFLEX®-N' are trademarks licensed by REMINC.

COPYRIGHT 2013 by RESEARCH ENGINEERING & MANUFACTURING INC.

Research Engineering & Manufacturing Inc.
55 Hammarlund Way, Tech II, Middletown, RI 02842 USA
Tel: 401-841-8880 • Fax: 401-841-5008
www.taptite.com • E-mail: reminc@reminc.net

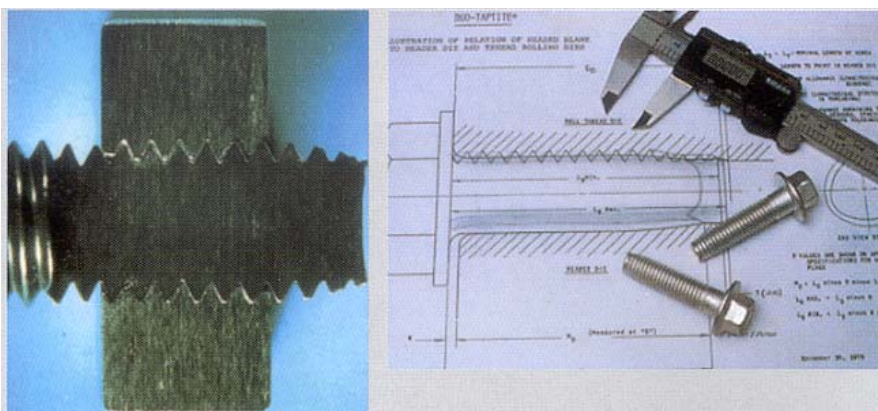
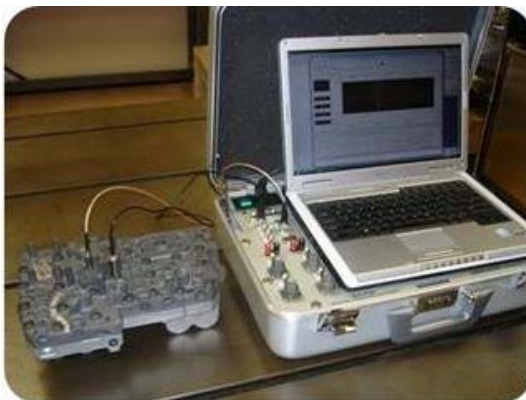

AVAILABILITY

Currently there are 68 qualified producers located in 20 countries utilizing the Technical Know-How, Patents, Trademarks, and Engineering and Marketing services of REMINC/CONTI. These producers delivered a volume in excess of 17,000,000,000 pieces of TRILOBULAR® fasteners in 2000, comprising a mix of products.

The proprietary products available in the program are marketed and sold, not as fastener items, but rather as **COST REDUCTIONS TO END-USERS OF ASSEMBLED PRODUCTS.**

The proprietary fasteners offered to the assemblers are the means to an end, i.e. used to generate cost reductions while at the same time providing reliably tightened joints.

ORDERING/SUPPLY

When ordering from qualified TRILOBULAR® fastener producers, be sure in all cases to specify the TAPTITE II® brand name, thread size, nominal length, head and point style, strength grade if CORFLEX®-N' or CORFLEX®-I' style, or any other special features required, finish, and

DISCLAIMER CLAUSE

The values shown in this brochure are for guidance only. They are not meant to be used for design criteria. Their use and reliance thereon for any purpose by anyone is entirely voluntary and at the sole risk of the user. REMINC/CONTI are not responsible for any loss, claim, or damage resulting from their use. Consult our application engineers or the application engineering department of one of our many qualified producers for your specific application data.

TECHNICAL ASSISTANCE

This brochure contains basic information needed to achieve the cost-savings potential of FASTITE® 2000™ fasteners.

To obtain further assistance and a list of qualified producers, visit our website at www.taptite.net or contact;

REMINC
Tel: 401-841-8880
Email: reminc@reminc.net

CONTI Fasteners AG
Tel: +41 (0)41/761 58 22
Email: conti@contifasteners.ch



CONTI Fasteners AG
Albisstrasse 15, 6340 Baar (ZG) Switzerland
Tel: +41 (0)41/761 5822 • Fax: +41 (0)41/761 3018
www.taptite.com • E-mail: conti@contifasteners.ch